

Walls

Data Sheet

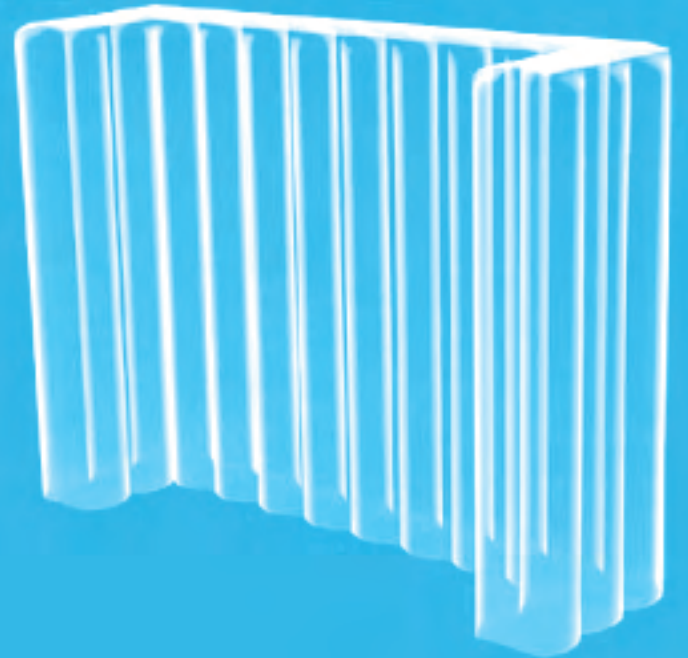

InspireInflatables

Visionary Inflatable Designs

Product Variations

Inspire is a brand new range of high performance, beautifully designed, and practical temporary event structures.

Light weight, easy to setup and remove each indoor range comes in it's own storage bag and includes everything that is required for use. The fans provided are designed to be low noise. Creatively designed, Inspire products are the worldwide leader in inflatable structures.

The Inspire Wall range includes:

Inspire Wall System

The wall system includes a range of flat event walls that easily zip together to offer small, medium and larger meeting areas. Creatively designed, easily and quickly installed an offering good sound insulation, the Inspire event walls offer a fantastic temporary solution.

1. Full Wall: 2.m long x 2.4m tall and 0.3m wide
2. Half Wall: 1.2m long x 2.4m tall and 0.3m wide
3. Zipped Corner Post: 0.3m x 0.3m and 2.m tall
4. Curved Wall: 2.4m x 2.4m and 0.3m wide

The Inspire range of structures can be tailored to suit your event needs, we offer branding with options including direct print and replaceable printed covers.

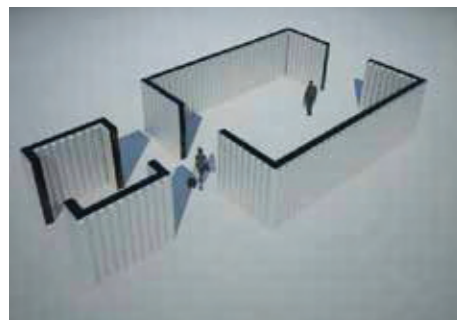

Inspire Cubic Wall System

The cubic wall system provide instant spaces by offering space and stability, these walls are designed to be used either singular or multiples, either free standing or zipped together providing a multitude of layouts and creative spaces.

1. 3m long x 2.4m tall with a 0.9m return either end
2. 6m long x 2.4m tall with a 1.8m return either end
3. 9m long x 2.4m tall with a 2.7m return either end
4. 12m long x 2.4m tall with a 3.6m return either end

General Arrangement

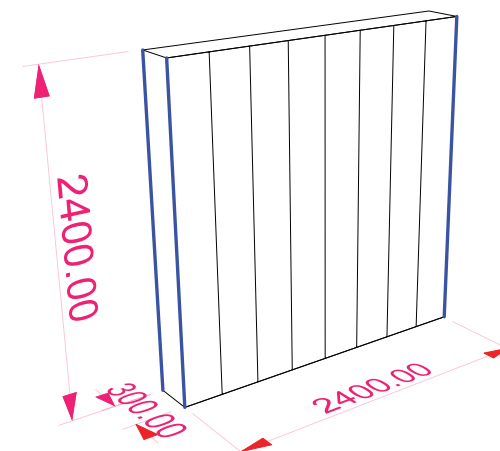

Full wall
(2.4m wide)

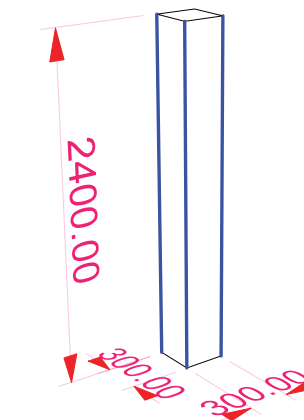

Corner Joint

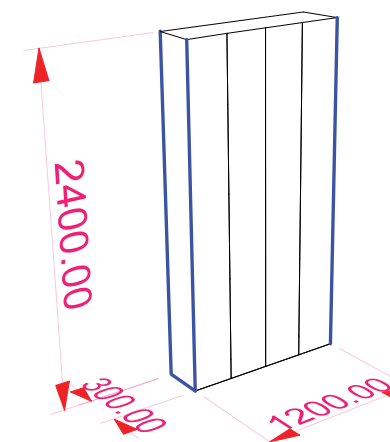

Half wall
(1.2m wide)

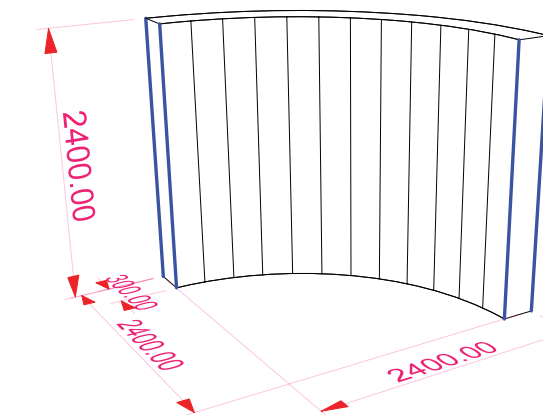

Curve wall
(2.4x2.4m)



General Arrangement

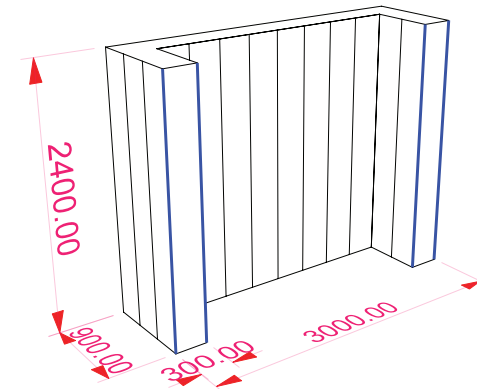
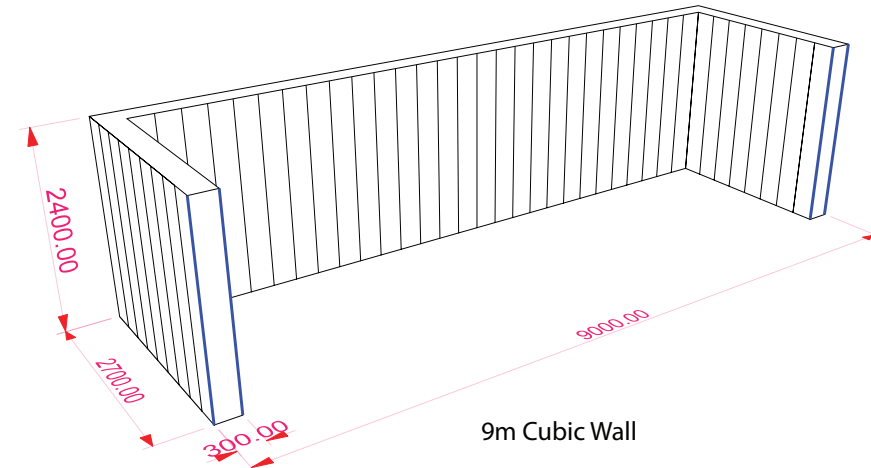
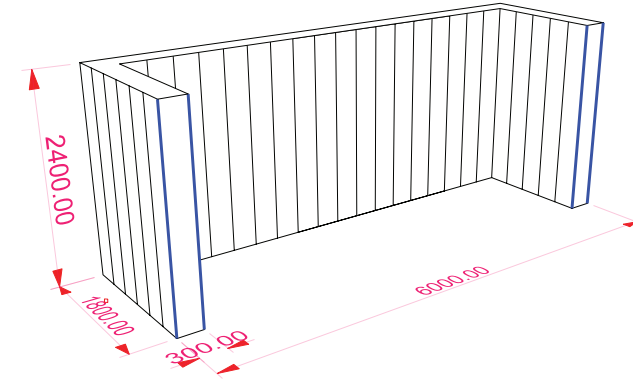
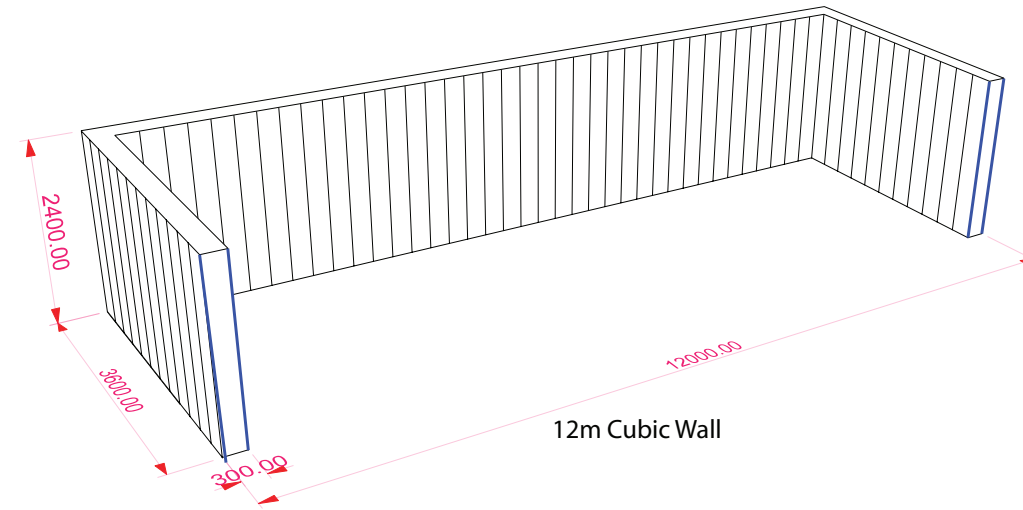

General Arrangement

1850mm X Ø50mm, SCAFFOLD POLE
Welded to....

4mm X Ø50mm, End cap, with
M8 centre hole

8mm X Ø300MM, Base plate, with
8mm countersunk centre hole.

M8X 30mm coutersunk
hex socket bolt

EXPLODED VIEW

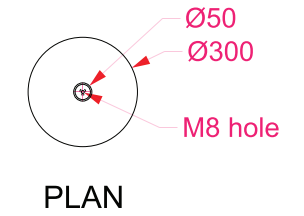
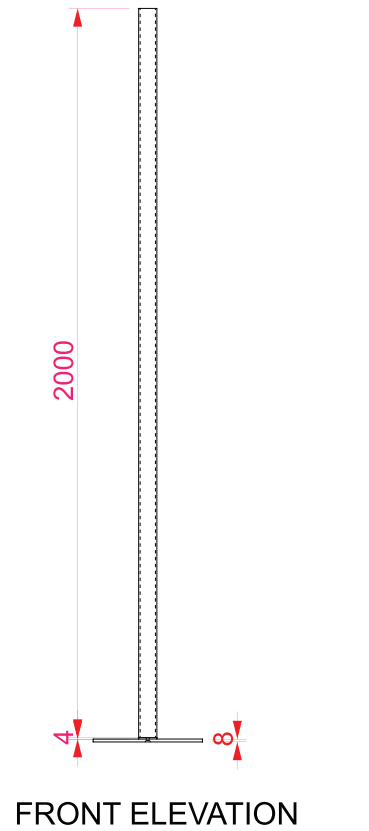

Product Specification (Air Wall)

PACKAGE

- 1x Wall Structure, 1x Packing Bag, 1x FG6 fan
- Corner Joint Structures sold without Bag or Fan

STRUCTURE

- Packed Size/Weight:**
- Full wall: 500 x 400 x 300mm. 15kg (est.)
 - Half wall: 400 x 300 x 200mm. 8kg (est.)
 - Curve wall: 500 x 500 x 400mm. 18kg (est.)
 - Corner joint: 200 x 200 x 100mm. 4kg (est.)

Inflated Size:

- Full wall: W2.4 x D0.3 x H2.4m
- Half wall: W1.2 x D0.3 x H2.4m
- Curve wall: W2.4 x D2.4 x H2.4m
- Corner joint: W0.3 x D0.3 x H2.4m

Fabrics:

- PVC, rip stop nylon FR treated

Colors:

- Combinations of white/black/silver

Please Note: Information is correct at time of publication. The company accepts no responsibility for variations in dimensions or weights. The company reserves the right to alter any dimensions or weights at any time without prior notice.

POWER & FANS

- Fans:** • 1x FG6 fan
Power: • 120v
Fan Weight: • 4kg per fan
Fan Dimensions: • 304mm x 304mm x 203mm

Please Note: It is the responsibility of the client or site management to ensure that the power used for fans is secure and tested. The above power consumption is for fans only and covers no extra electrical items. No other item should be connected to the fan power lines. The company accepts no responsibility for damages to equipment or damages to inflatable structures, injuries to persons or loss of earnings due to electrical power faults.

INSTALLATION & DERIG

- Crew:** • 1 persons (min)
Set Up Time: • From 10 mins
Inflation Time: • 5 mins for structure when fixed
Derig Time: • From 10 mins

PRODUCT ENHANCEMENTS

- Branding • Temporary/Permanent Banners • Lighting
- Complete Interior Design and Production Service • Custom Colored Fabric
- All Spares of Basic Package

Please Note: Refer to separate later page for more detail on product enhancement. Please note the above technical data can be effected by additional product enhancements. The company reserves the right to add or remove product enhancements from product range without prior notice.



Product Specification (Cube Wall)

PACKAGE

- 1x Wall Structure, 1x Packing Bag, 1x FG6 Fan
- Corner Joint Structures sold without Bag or Fan

STRUCTURE

- Packed Size/Weight:**
- 3m Wall: 500 x 300 x 300mm. 15kg (est.)
 - 6m Wall: 500 x 400 x 400mm. 18kg (est.)
 - 9m Wall: 600 x 500 x 400mm. 22kg (est.)
 - 12m Wall: 600 x 600 x 400mm. 26kg (est.)

Inflated Size:

- 3m Wall: W3 x D0.9 x H2.4m
- 6m Wall: W6 x D1.8 x H2.4m
- 9m Wall: W9 x D2.7 x H2.4m
- 12m Wall: W12 x D3.6 x H2.4m

Fabrics:

- PVC, rip stop nylon FR treated

Colors:

- Combinations of white/black/silver

Please Note: Information is correct at time of publication. The company accepts no responsibility for variations in dimensions or weights. The company reserves the right to alter any dimensions or weights at any time without prior notice.

POWER & FANS

- Fans:** • 1x FG6 fan
Power: • 120v
Fan Weight: • 4kg per fan
Fan Dimensions: • 304mm x 304mm x 203mm

Please Note: It is the responsibility of the client or site management to ensure that the power used for fans is secure and tested. The above power consumption is for fans only and covers no extra electrical items. No other item should be connected to the fan power lines. The company accepts no responsibility for damages to equipment or damages to inflatable structures, injuries to persons or loss of earnings due to electrical power faults.

INSTALLATION & DERIG

- Crew:** • 1 persons (min)
Set Up Time: • From 10 mins
Inflation Time: • 5 mins for structure when fixed
Derig Time: • From 10 mins

PRODUCT ENHANCEMENTS

- Branding • Temporary/Permanent Banners • Lighting
- Complete Interior Design and Production Service • Custom Colored Fabric
- All Spares of Basic Package

Please Note: Refer to separate later page for more detail on product enhancement. Please note the above technical data can be effected by additional product enhancements. The company reserves the right to add or remove product enhancements from product range without prior notice.



Product Enhancement

Branding

Branding can be applied permanently to any of the Inflatable structures as screen print or digital printing at the source of production.

Temporary branding can be added as vinyl or Dacron adhesive panels at any stage. Please note that not all artwork is suitable for printing on our structure range. It is advised sample artwork be supplied in an .eps format so we can advise the best solution.

Custom colors and materials

All our structures are manufactured in ripstop nylon and reinforced PVC. As standard they are made in white and grey . Although a full colour range is available, this may alter lead times and costs.

Other materials are available and we are happy to discuss specific needs / projects and will advise on what we feel is the most appropriate solution. All fabrics are tested for performance of flammability for textiles used in the construction of marquees and similar textiles structures to standards: BS 7837:1996 / BS 5438:1989.

Lighting

As an optional extra we can provide internal LED lighting systems which will transform the look and feel of your inflatable structure. The ambient lighting effect can be either one color change or mixed to produce your perfect environment.

Flooring

Flooring is available upon request and is offered to suit all event needs. We offer simple snap lock flooring. This offers light weight flooring and ideal for grass and concrete. It can be further enhanced by adding a finishing carpet.

Transport

By its nature an inflatable structure packs down to considerably less than its inflated size. The largest of our range packs down to less than 2M³ which makes the structures ideal to store and use again. Each product will be supplied in its own storage bag and will be easily transported in an out of any venue.

Warranty

Inspire offers a 12 month warranty on the manufacture process and materials if the user manual and install guides are followed. Due to the nature of weather and installation conditions, Inspire reserves the right to carry out an onsite inspection and report which way the warranty will be meet.

