

# GeoDomes

## Data Sheet



# Product Variations

## GeoDomes

The Geo Dome range offers an extremely strong semi permanent event structure, these units can be used in all weathers and can be installed in any location. Providing a contemporary space for any event.

The Geodesic Dome is a true geodesic pattern unlike many of our competitors, this means the parts are more uniform which is important for the speed of installation and making the products modular. Providing a much easier to install product and a versatile purchase. The frame work is available in both light weight Aluminium for when weight is a concern and steel, both can be left as plain metal or powder coated to provide a colour finish.

The covers are made from top quality materials and come with a 15 year warranty, these can be white, transparent or a mixture of any color.

### Available in the following sizes:

- 6m diameter x 3m tall
- 8m diameter x 4m tall
- 10m diameter x 5m tall
- 12m diameter x 6m tall
- 15m diameter x 7m tall
- 20m diameter x 10m tall

The GeoDomes range of structures can be tailored to suit your event needs, we offer branding with options including direct print and replaceable printed covers.

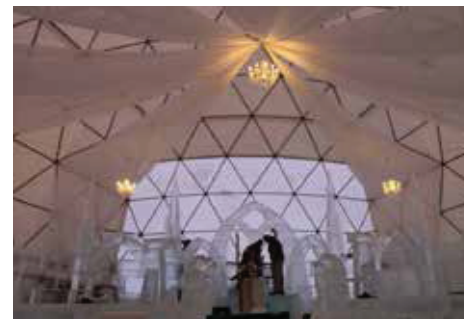

# General Arrangement (6m)

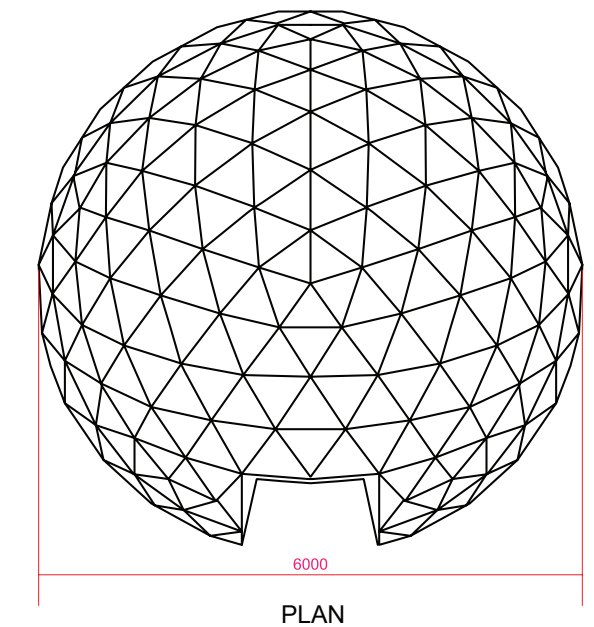
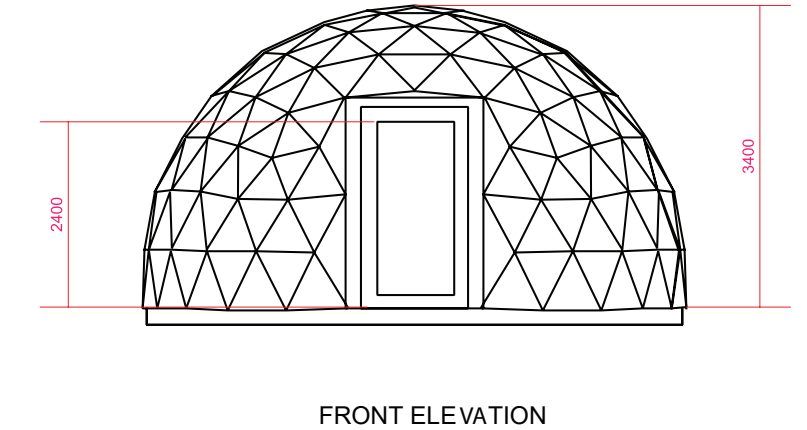
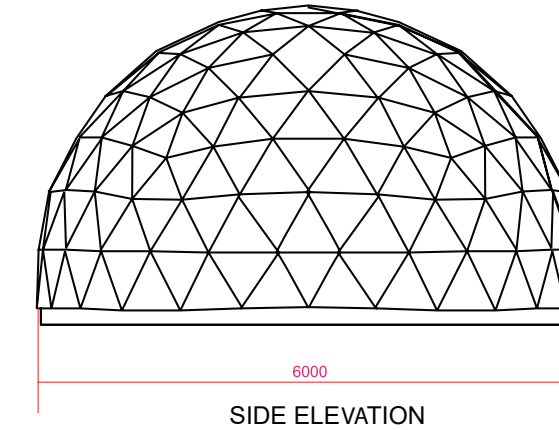

# Product Variations

## GeoDomes

The Geo Dome range offers an extremely strong semi permanent event structure, these units can be used in all weathers and can be installed in any location. Providing a contemporary space for any event.

The Geodesic Dome is a true geodesic pattern unlike many of our competitors, this means the parts are more uniform which is important for the speed of installation and making the products modular. Providing a much easier to install product and a versatile purchase. The frame work is available in both light weight Aluminium for when weight is a concern and steel, both can be left as plain metal or powder coated to provide a colour finish.

The covers are made from top quality materials and come with a 15 year warranty, these can be white, transparent or a mixture of any color.

### Available in the following sizes:

- 6m diameter x 3m tall
- 8m diameter x 4m tall
- 10m diameter x 5m tall
- 12m diameter x 6m tall
- 15m diameter x 7m tall
- 20m diameter x 10m tall

The GeoDomes range of structures can be tailored to suit your event needs, we offer branding with options including direct print and replaceable printed covers.

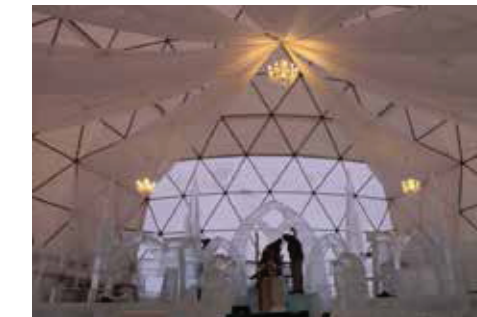

# General Arrangement (6m)

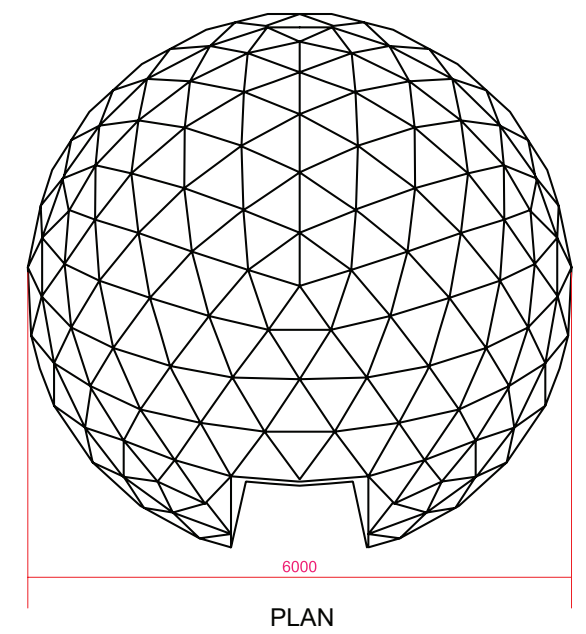
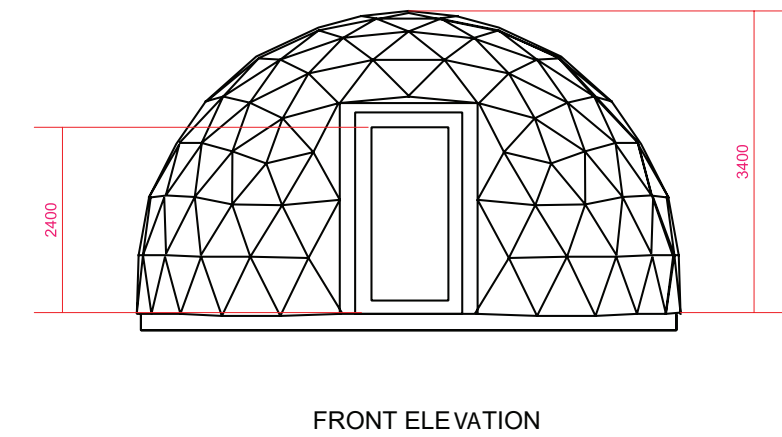
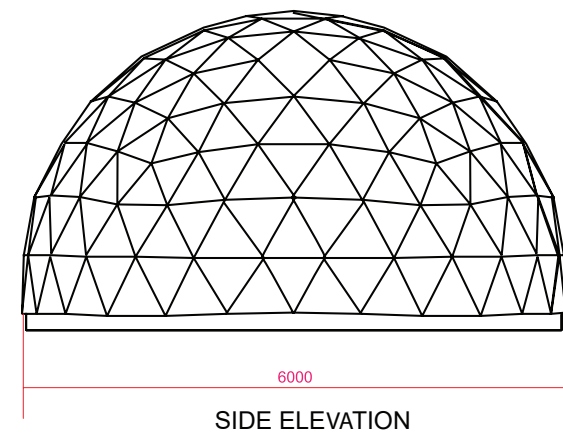

# General Arrangement (8m)

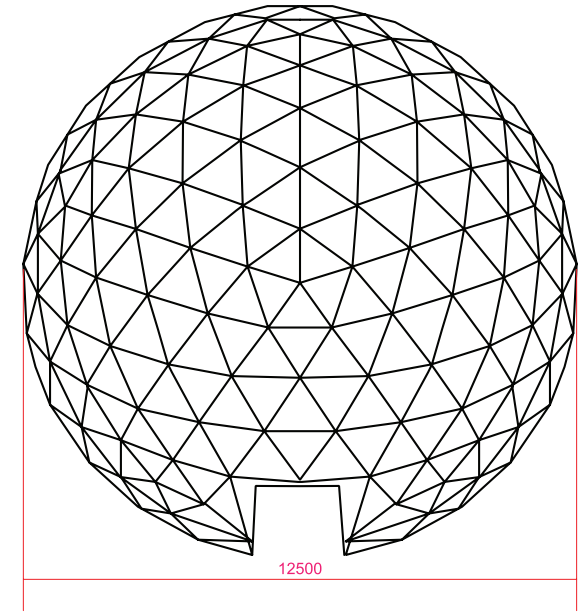
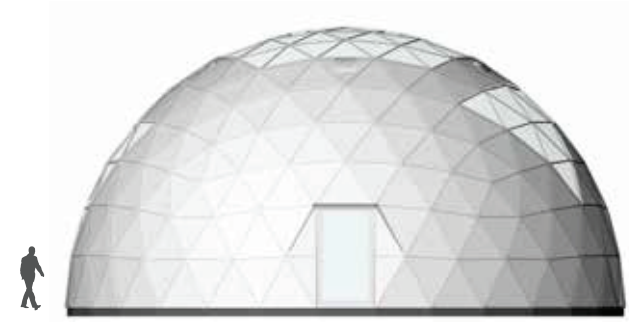
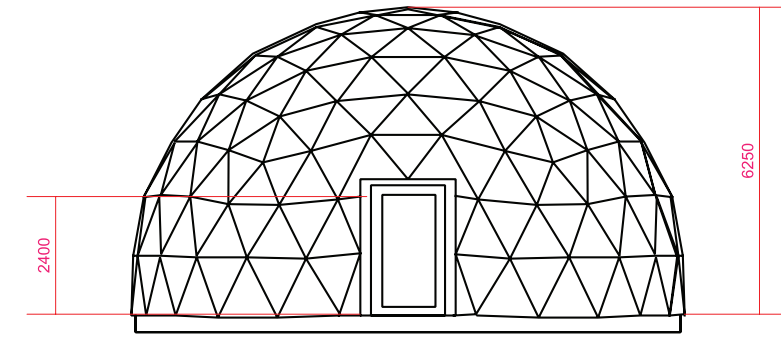
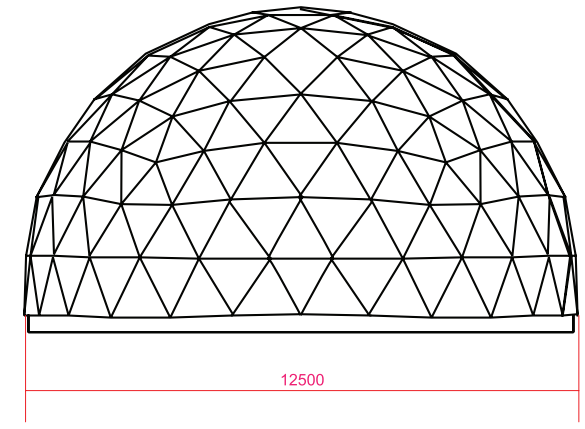

# General Arrangement (10m)

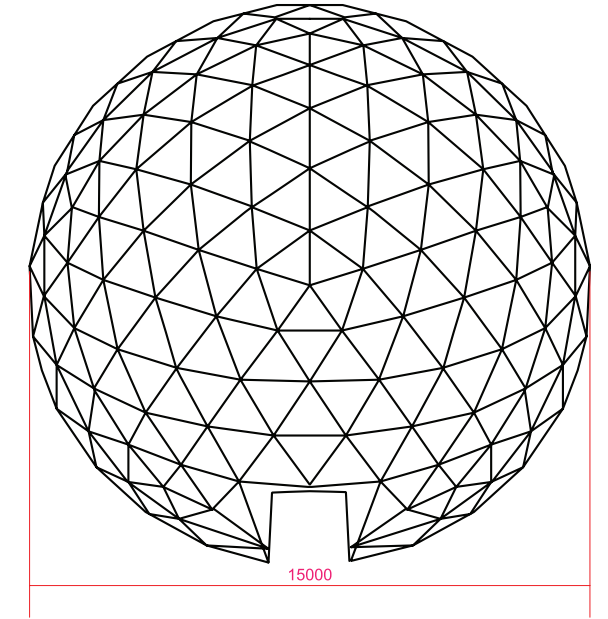
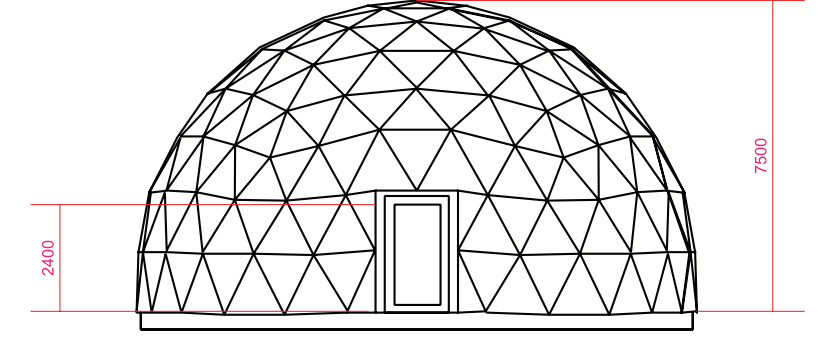
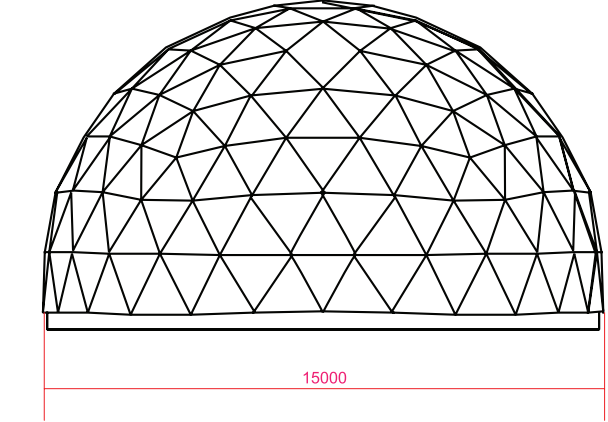

# General Arrangement (20m)

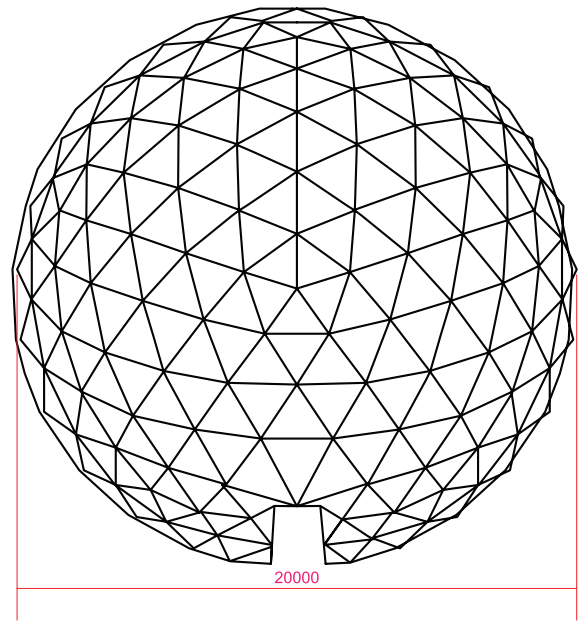
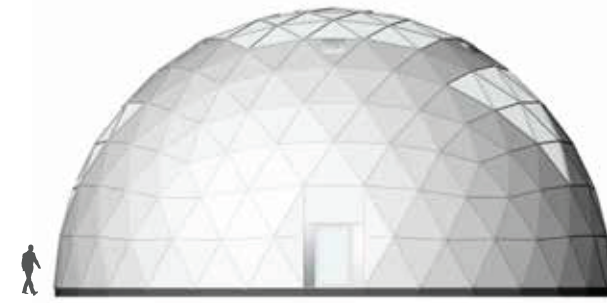
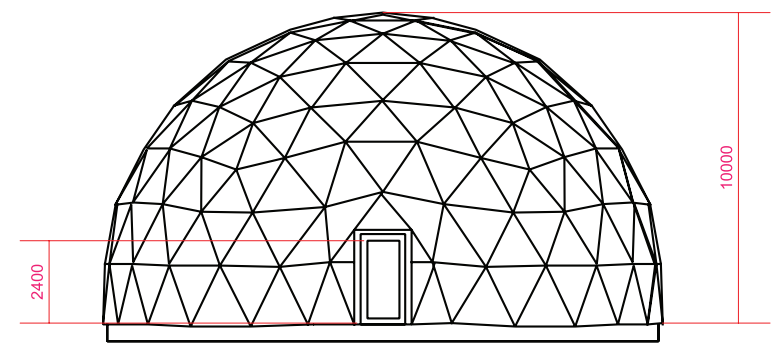
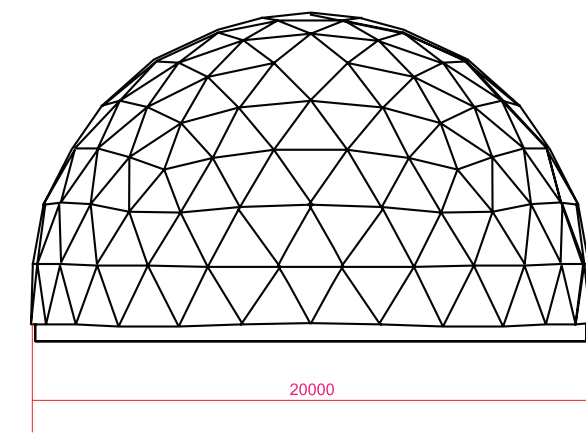

# Product Capacity (6m)

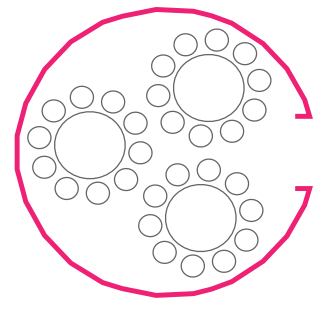

**Restaurant Capacity:**  
3 Tables  
30 Seats

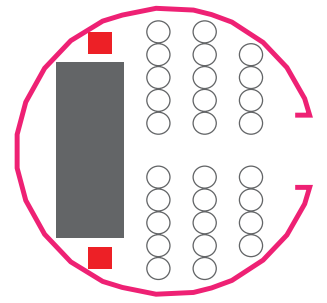

**Conference Capacity:**  
4x1.5m Stage  
28 Seats

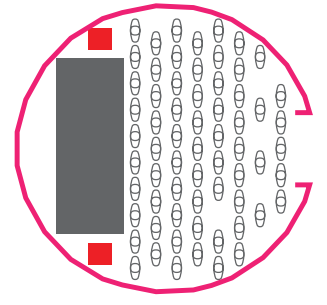

**Concert Capacity:**  
4x1.5m Stage  
66 People

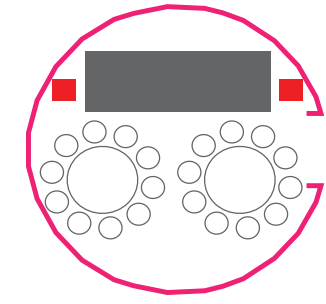

**Cabaret Capacity:**  
4x1.5m Stage  
2 Tables  
20 Seats

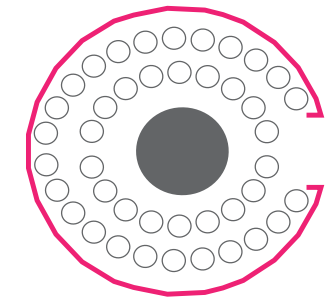

**Arena Capacity:**  
2m Diameter Stage  
42 Seats

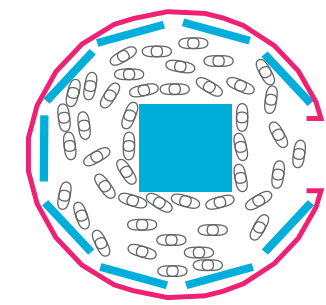

**Exhibition Capacity:**  
9x Exhibition Stands  
45 People

● Structure Footprint    
 ⊙ Table + 10 Seats    
 ● Stage    
 ■ Speakers    
 ■ Exhibit    
 ⊞ People standing.



# Product Capacity (8m)

# Product Capacity (10m)

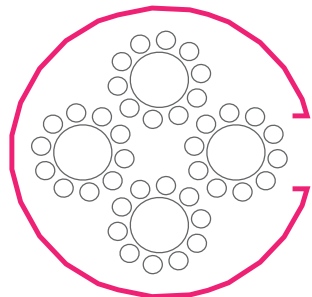

**Restaurant Capacity:**  
4 Tables  
40 Seats

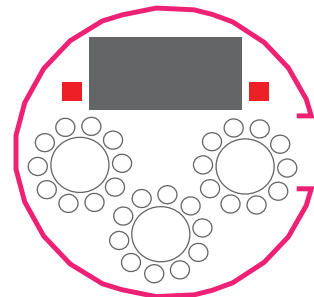

**Caberet Capacity:**  
4x2m Stage  
3 Tables  
30 Seats

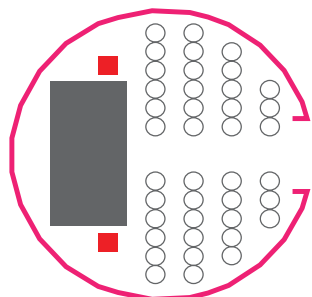

**Conference Capacity:**  
4x2m Stage  
40 Seats

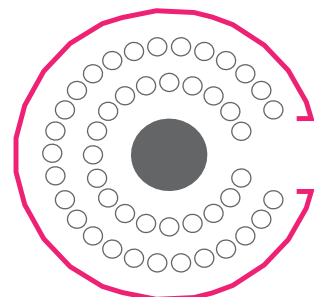

**Arena Capacity:**  
2m Diameter Stage  
46 Seats

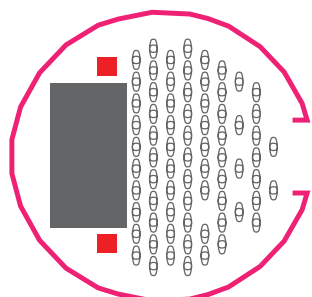

**Concert Capacity:**  
4x2m Stage  
80 People

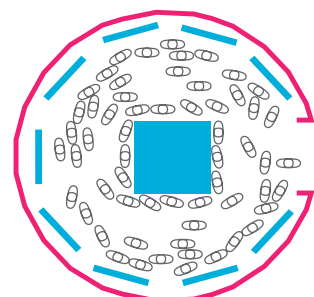

**Exhibition Capacity:**  
9x Exhibition Stands  
60 People

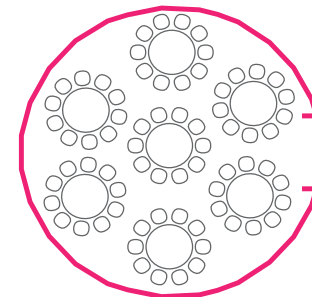

**Restaurant Capacity:**  
7 Tables  
70 Seats

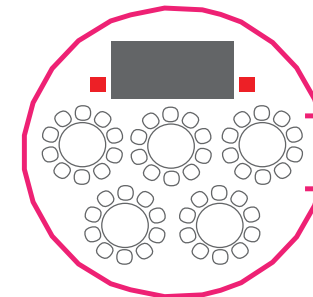

**Caberet Capacity:**  
4x2m Stage  
5 Tables  
50 Seats

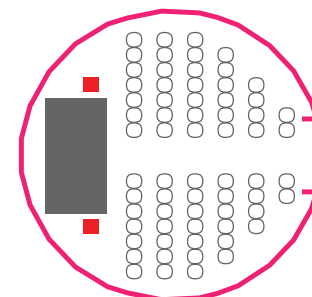

**Conference Capacity:**  
4x2m Stage  
66 Seats

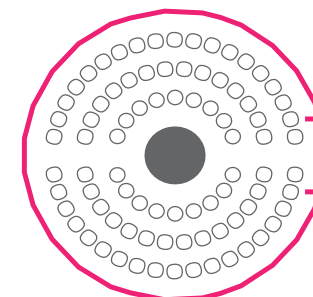

**Arena Capacity:**  
2m Diameter Stage  
84 Seats

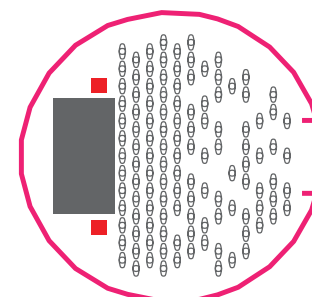

**Concert Capacity:**  
4x2m Stage  
120 People

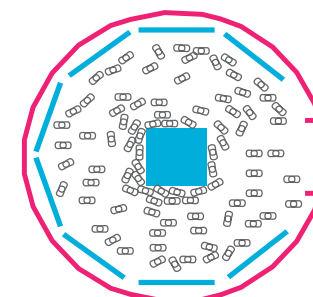

**Exhibition Capacity:**  
8x Exhibition Stands  
90 People

# Product Capacity (12.5m)

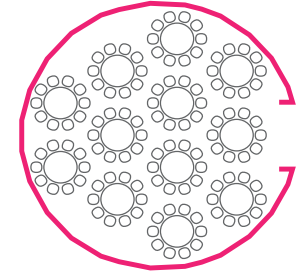

**Restaurant Capacity:**  
12 Tables  
120 Seats

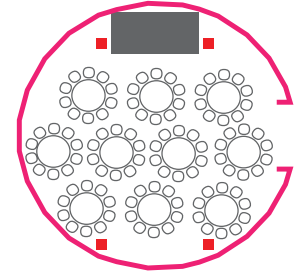

**Caberet Capacity:**  
4x2m Stage  
10 Tables  
100 Seats

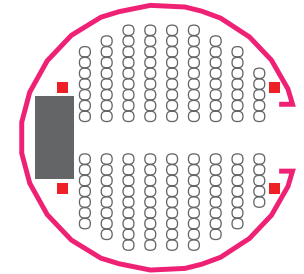

**Conference Capacity:**  
4x2m Stage  
142 Seats

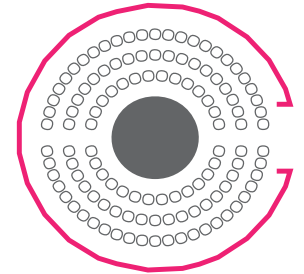

**Arena Capacity:**  
4m Diameter Stage  
116 Seats

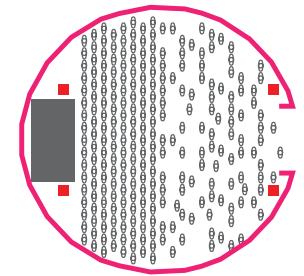

**Concert Capacity:**  
4x2m Stage  
250 People

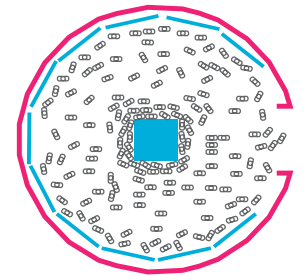

**Exhibition Capacity:**  
12x Exhibition Stands  
187 People

● Structure Footprint    🍷 Table + 10 Seats    ● Stage    ■ Speakers    ■ Exhibit    👤 People standing.

# Product Capacity (15m)

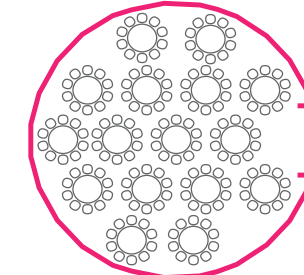

**Restaurant Capacity:**  
16 Tables  
150 Seats

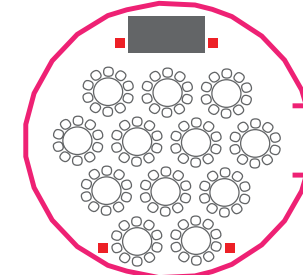

**Caberet Capacity:**  
4x2m Stage  
12 Tables  
120 Seats

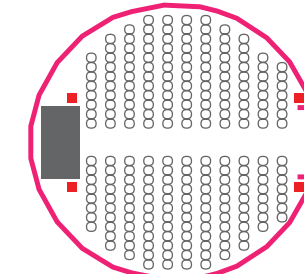

**Conference Capacity:**  
4x2m Stage  
226 Seats

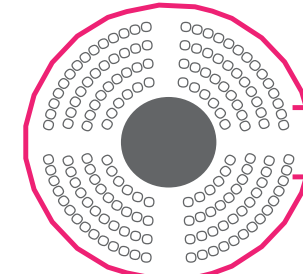

**Arena Capacity:**  
4m Diameter Stage  
160 Seats

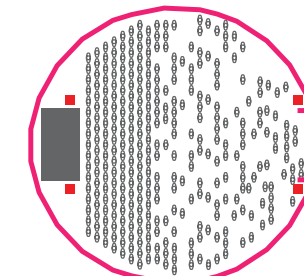

**Concert Capacity:**  
4x2m Stage  
325 People

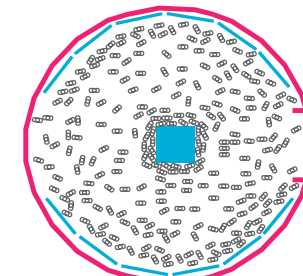

**Exhibition Capacity:**  
14x Exhibition Stands  
244 People

● Structure Footprint    🍷 Table + 10 Seats    ● Stage    ■ Speakers    ■ Exhibit    👤 People standing.

# Product Capacity (20m)

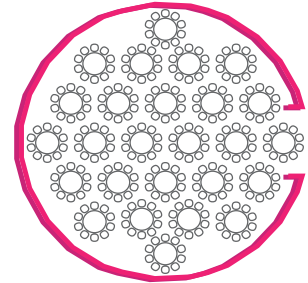

**Restaurant Capacity:**  
26 Tables  
260 Seats

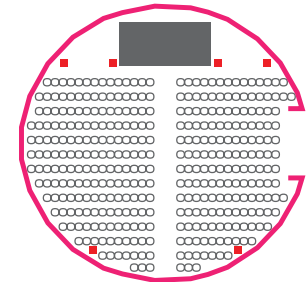

**Conference Capacity:**  
6x3m Stage  
364 Seats

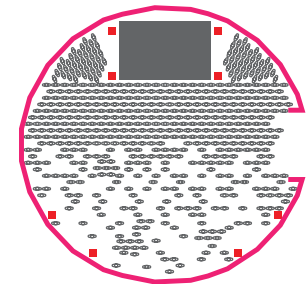

**Concert Capacity:**  
6x4m Stage  
544 People

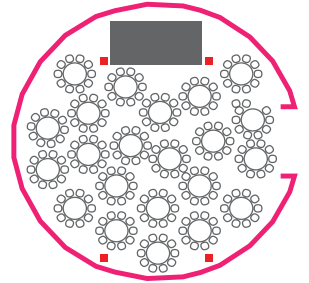

**Cabaret Capacity:**  
6x3m Stage  
22 Tables  
220 Seats

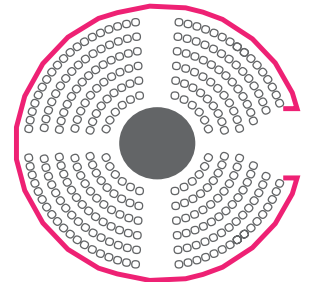

**Arena Capacity:**  
5m Diameter Stage  
304 Seats

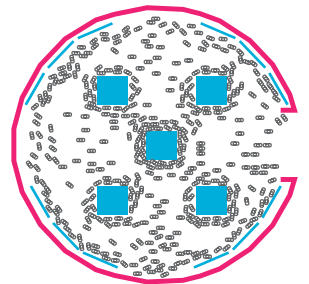

**Exhibition Capacity:**  
16x Exhibition Stands  
406 People

- Structure Footprint
- Table + 10 Seats
- Stage
- Speakers
- Exhibit
- People standing.

# Product Specification (6m)

## STRUCTURE

- Structure Weight:** • 570kg (stainless steel. Steel or aluminum available)
- Cover Weight:** • 50kg (est.)
- Internal Floor Area:** • 28m<sup>2</sup>
- Plot size Required:** • 6.5m x 6.5m plus
- Entrance/Exit Size:** • W1.2m, H2.4m
- Cover Material:** • PVC tarpaulin B1, UV
- Metal:** • Stainless steel pipes
- Colors:** • Combinations of white/black/silver
- Ground Fixings:** • Available upon request

## STRUCTURE

- Frame work in chosen size • Cover in chosen color
- Crate • User Manual • Warranty

## OPTIONAL EXTRAS

- Powder Coated Frame • Door System • Air Circulation Fans
- Installation training

## Powder coating available in:

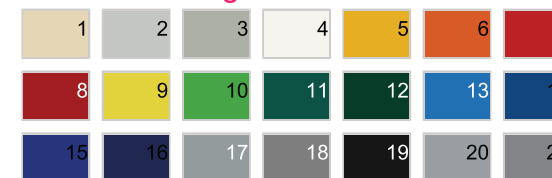

**Please Note:** It is the responsibility of the client or site management to ensure that the power used for fans is secure and tested. The above power consumption is for fans only and covers no extra electrical items. No other item should be connected to the fan power lines. The company accepts no responsibility for damages to equipment or damages to inflatable structures, injuries to persons or loss of earnings due to electrical power faults.

## INSTALLATION & DERIG

- Crew:** • 4 persons (min)
- Set Up Time:** • 12 hours
- Derig Time:** • 12 hours

## PRODUCT ENHANCEMENTS

- Branding - Temporary/ Permanent / Banners / Printed Covers
- Ground Anchor Fixing • Lighting • Flooring • Custom Colored Fabric
- All Spares of Basic Package

**Please Note:** Refer to separate later page for more detail on product enhancement. Please note the above technical data can be effected by additional product enhancements. The company reserves the right to add or remove product enhancements from product range without prior notice.





# Product Specification (8m)

## STRUCTURE

- Structure Weight:** • 700kg (stainless steel. Steel or aluminum available)
- Cover Weight:** • 85kg (est.)
- Internal Floor Area:** • 50m<sup>2</sup>
- Plot size Required:** • 8.5m x 8.5m plus
- Entrance/Exit Size:** • W1.2m, H2.4m
- Cover Material:** • PVC tarpaulin B1, UV
- Metal:** • Stainless steel pipes
- Colors:** • Combinations of white/black/silver
- Ground Fixings:** • Available upon request

## STRUCTURE

- Frame work in chosen size • Cover in chosen color
- Crate • User Manual • Warranty

## OPTIONAL EXTRAS

- Powder Coated Frame • Door System • Air Circulation Fans
- Installation training

### Powder coating available in:

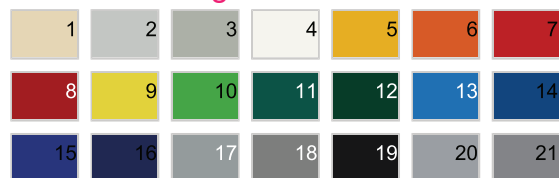

**Please Note:** It is the responsibility of the client or site management to ensure that the power used for fans is secure and tested. The above power consumption is for fans only and covers no extra electrical items. No other item should be connected to the fan power lines. The company accepts no responsibility for damages to equipment or damages to inflatable structures, injuries to persons or loss of earnings due to electrical power faults.

## INSTALLATION & DERIG

- Crew:** • 4 persons (min)
- Set Up Time:** • 18 hours
- Derig Time:** • 12 hours

## PRODUCT ENHANCEMENTS

- Branding - Temporary/ Permanent / Banners / Printed Covers
- Ground Anchor Fixing • Lighting • Flooring • Custom Colored Fabric
- All Spares of Basic Package

**Please Note:** Refer to separate later page for more detail on product enhancement. Please note the above technical data can be effected by additional product enhancements. The company reserves the right to add or remove product enhancements from product range without prior notice.



# Product Specification (10m)

## STRUCTURE

- Structure Weight:** • 1100kg (stainless steel. Steel or aluminum available)
- Cover Weight:** • 130kg (est.)
- Internal Floor Area:** • 77m<sup>2</sup>
- Plot size Required:** • 10.5m x 10.5m plus
- Entrance/Exit Size:** • W1.2m, H2.4m
- Cover Material:** • PVC tarpaulin B1, UV
- Metal:** • Stainless steel pipes
- Colors:** • Combinations of white/black/silver/frosted
- Ground Fixings:** • Available upon request

## STRUCTURE

- Frame work in chosen size • Cover in chosen color
- Crate • User manual • Warranty

## OPTIONAL EXTRAS

- Powder Coated Frame • Door System • Air Circulation Fans
- Installation training

### Powder coating available in:

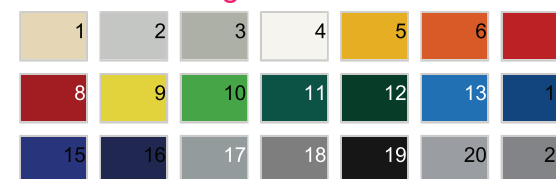

**Please Note:** It is the responsibility of the client or site management to ensure that the power used for fans is secure and tested. The above power consumption is for fans only and covers no extra electrical items. No other item should be connected to the fan power lines. The company accepts no responsibility for damages to equipment or damages to inflatable structures, injuries to persons or loss of earnings due to electrical power faults.

## INSTALLATION & DERIG

- Crew:** • 4 persons (min)
- Set Up Time:** • 1 day
- Derig Time:** • 12 hours

## PRODUCT ENHANCEMENTS

- Branding - Temporary/ Permanent / Banners / Printed Covers
- Ground Anchor Fixing • Lighting • Flooring • Custom Colored Fabric
- All Spares of Basic Package

**Please Note:** Refer to separate later page for more detail on product enhancement. Please note the above technical data can be effected by additional product enhancements. The company reserves the right to add or remove product enhancements from product range without prior notice.



# Product Specification (12.5m)

## STRUCTURE

- Structure Weight:** • 1350kg (Stainless steel, Steel or Aluminum available)
- Cover Weight:** • 210kg (est.)
- Internal Floor Area:** • 120m<sup>2</sup>
- Plot size Required:** • 13m x 13m plus
- Entrance/Exit Size:** • W1.2m, H2.4m
- Cover Material:** • PVC tarpaulin B1, UV
- Metal:** • Stainless steel pipes
- Colors:** • Combinations of white/black/silver
- Ground Fixings:** • Available upon request

## STRUCTURE

- Frame work in chosen size • Cover in chosen color
- Crate • User Manual • Warranty

## OPTIONAL EXTRAS

- Powder Coated Frame • Door System • Air Circulation Fans
- Installation training

### Powder coating available in:

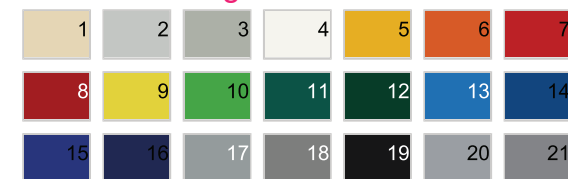

**Please Note:** It is the responsibility of the client or site management to ensure that the power used for fans is secure and tested. The above power consumption is for fans only and covers no extra electrical items. No other item should be connected to the fan power lines. The company accepts no responsibility for damages to equipment or damages to inflatable structures, injuries to persons or loss of earnings due to electrical power faults.

## INSTALLATION & DERIG

- Crew:** • 4 - 6 persons (min)
- Set Up Time:** • 1 day
- Derig Time:** • 12 hours

## PRODUCT ENHANCEMENTS

- Branding - Temporary/ Permanent / Banners / Printed Covers
- Ground Anchor Fixing • Lighting • Flooring • Custom Colored Fabric
- All Spares of Basic Package

**Please Note:** Refer to separate later page for more detail on product enhancement. Please note the above technical data can be effected by additional product enhancements. The company reserves the right to add or remove product enhancements from product range without prior notice.



# Product Specification (15m)

## STRUCTURE

- Structure Weight:** • 1550kg (Stainless steel, Steel or Aluminum available)
- Cover Weight:** • 300kg (est.)
- Internal Floor Area:** • 170m<sup>2</sup>
- Plot size Required:** • 15.5m x 15.5m plus
- Entrance/Exit Size:** • W1.2m, H2.4m
- Cover Material:** • PVC tarpaulin B1, UV
- Metal:** • Stainless steel pipes
- Colors:** • Combinations of white/black/silver/frosted
- Ground Fixings:** • Available upon request

## STRUCTURE

- Frame work in chosen size • Cover in chosen color
- Crate • User manual • Warranty

## OPTIONAL EXTRAS

- Powder Coated Frame • Door System • Air Circulation Fans
- Installation training

### Powder coating available in:



**Please Note:** It is the responsibility of the client or site management to ensure that the power used for fans is secure and tested. The above power consumption is for fans only and covers no extra electrical items. No other item should be connected to the fan power lines. The company accepts no responsibility for damages to equipment or damages to inflatable structures, injuries to persons or loss of earnings due to electrical power faults.

## INSTALLATION & DERIG

- Crew:** • 6 persons (min)
- Set Up Time:** • 1 day
- Derig Time:** • 12 hours

## PRODUCT ENHANCEMENTS

- Branding - Temporary/ Permanent / Banners / Printed Covers
- Ground Anchor Fixing • Lighting • Flooring • Custom Colored Fabric
- All Spares of Basic Package

**Please Note:** Refer to separate later page for more detail on product enhancement. Please note the above technical data can be effected by additional product enhancements. The company reserves the right to add or remove product enhancements from product range without prior notice.



# Product Specification (20m)

## STRUCTURE

- Structure Weight:** • 2550kg (stainless steel. Steel or aluminum available)
- Cover Weight:** • 530kg (est.)
- Internal Floor Area:** • 300m<sup>2</sup>
- Plot size Required:** • 20.5m x 20.5m plus
- Entrance/Exit Size:** • W1.2m, H2.4m
- Cover Material:** • PVC tarpaulin B1, UV
- Metal:** • Stainless steel pipes
- Colors:** • Combinations of white/black/silver
- Ground Fixings:** • Available upon request

## STRUCTURE

- Frame work in chosen size • Cover in chosen color
- Crate • User Manual • Warranty

## OPTIONAL EXTRAS

- Powder Coated Frame • Door System • Air Circulation Fans
- Installation training

## Powder coating available in:

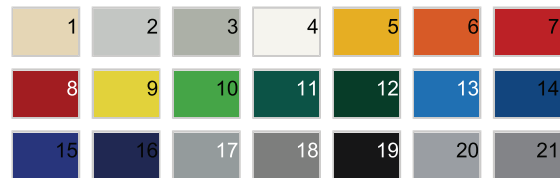

**Please Note:** It is the responsibility of the client or site management to ensure that the power used for fans is secure and tested. The above power consumption is for fans only and covers no extra electrical items. No other item should be connected to the fan power lines. The company accepts no responsibility for damages to equipment or damages to inflatable structures, injuries to persons or loss of earnings due to electrical power faults.

## INSTALLATION & DERIG

- Crew:** • 4 persons (min)
- Set Up Time:** • 18 hours
- Derig Time:** • 12 hours

## PRODUCT ENHANCEMENTS

- Branding - Temporary/ Permanent / Banners / Printed Covers
- Ground Anchor Fixing • Lighting • Flooring • Custom Colored Fabric
- All Spares of Basic Package

**Please Note:** Refer to separate later page for more detail on product enhancement. Please note the above technical data can be effected by additional product enhancements. The company reserves the right to add or remove product enhancements from product range without prior notice.



# Product Enhancement

## Branding

Branding can be applied permanently to any of the Inflatable structures as screen print or digital printing at the source of production.

Temporary branding can be added as vinyl or Dacron adhesive panels at any stage. Please note that not all artwork is suitable for printing on our structure range. It is advised sample artwork be supplied in an .eps format so we can advise the best solution. Full replaceable covers are available to the range. These can be branded and printed to ensure your structure matches your brand.

## Custom colors and materials

All our structures are manufactured in ripstop nylon and reinforced PVC. As standard they are made in white and grey. Although a full color range is available, this may alter lead times and costs.

Other materials are available and we are happy to discuss specific needs / projects and will advise on what we feel is the most appropriate solution. All fabrics are tested for performance of flammability for textiles used in the construction of marquees and similar textiles structures to standards: BS 7837:1996 / BS 5438:1989.

## Lighting

As an optional extra we can provide internal LED lighting systems which will transform the look and feel of your inflatable structure. The ambient lighting effect can be either one colour change or mixed to produce your perfect environment.

## Trussing

The Inspire range of inflatable structures have been designed to be used as free standing products, trussing is not required to use them, however trussing can be added to enhance the environment. These can be used to hang PA equipment or other lighting options.

## Doors & Closures

All of the Inspire Inflatables range comes complete with zip in/ out doors as standard. Inspire also offers full aluminium double door systems. These provide fire safety openers and are fully lockable which provides increased security. The door systems are bespoke and made to be installed perfectly into our doorways.

## Flooring

Flooring is available upon request and is offered to suit all event needs. We offer simple snap lock flooring. This offers light weight flooring and ideal for grass and concrete. It can be further enhanced by adding a finishing carpet.

## Warranty

Inspire Inflatables offers a 12 month warranty on the manufacture process and materials if the user manual and install guides are followed. Due to the nature of weather and installation conditions, Inspire reserves the right to carry out an onsite inspection and report which way the warranty will be met.

