

# Panoramic

## Data Sheet

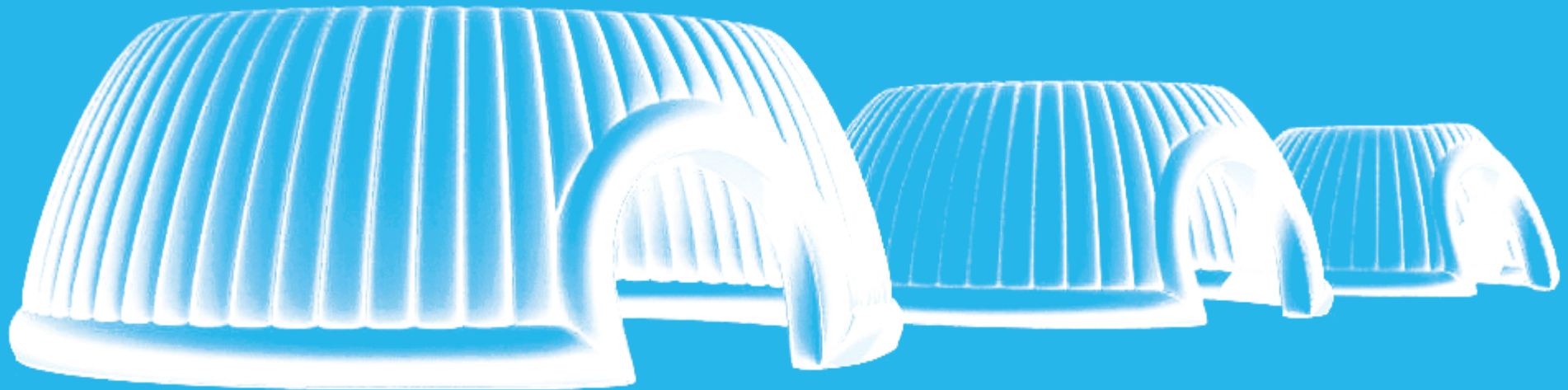

# Product Variations

Inspire is a brand new range of high performance, beautifully designed, and practical temporary event structures.

Light weight, easy to setup and remove, each of the indoor range comes in its own storage bag and includes everything that is required for use. The fans provided are designed to be low noise. Creatively designed, Inspire's products are the worldwide leader in inflatable structures.

Inspire Panoramic range includes:

Available in the following sizes:

- 6m wide x 2.8m tall
- 8m wide x 3.2m tall
- 10m wide x 3.5m tall

Inspire range of structures can be tailored to suit your event needs. We offer branding with options including direct print and replaceable printed covers. The Inspire range also offers great flexibility as all products can be seamlessly joined together, providing wonderful multi-room environments.



# General Arrangement (6m)

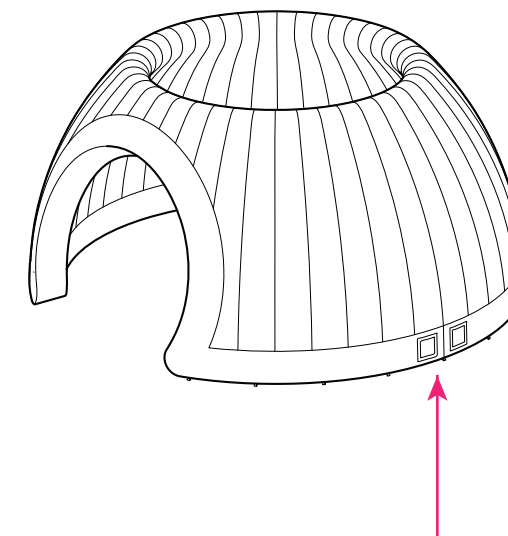
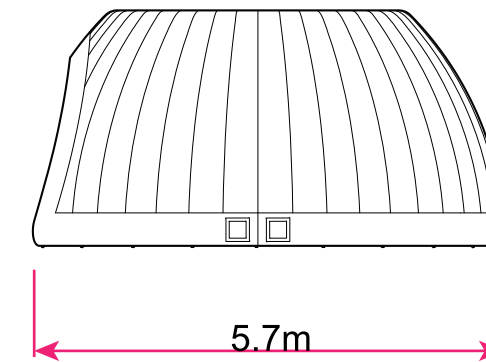
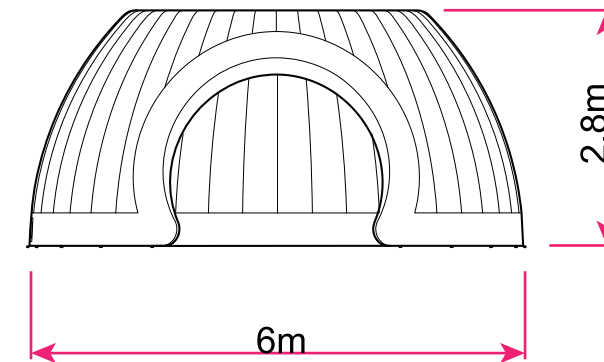

Fan positioning available at 4 points at the sides of the structure - SEE DETAIL 2

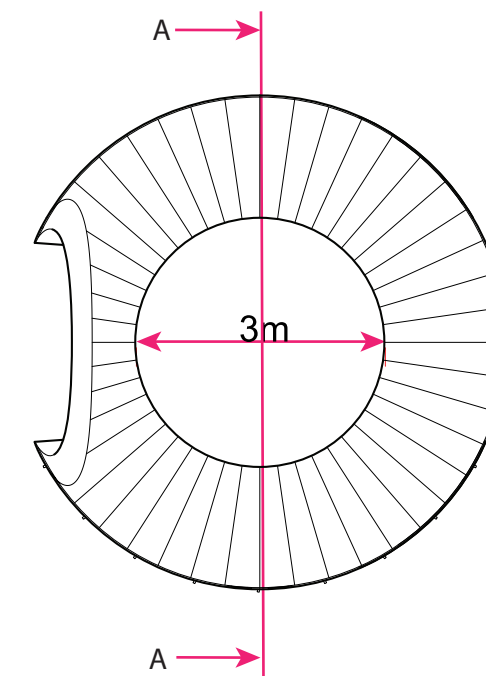

# General Arrangement (8m)

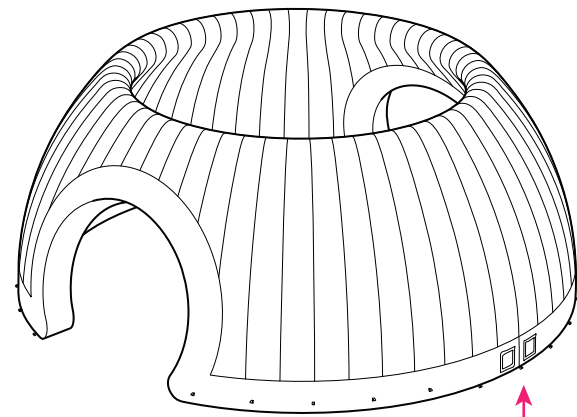
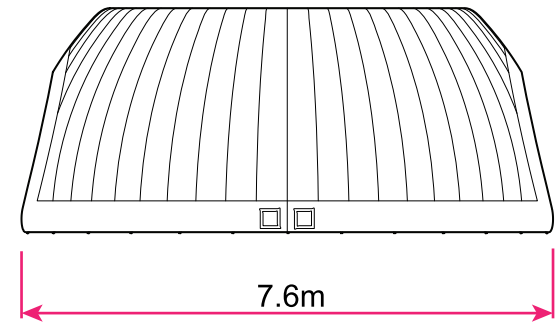
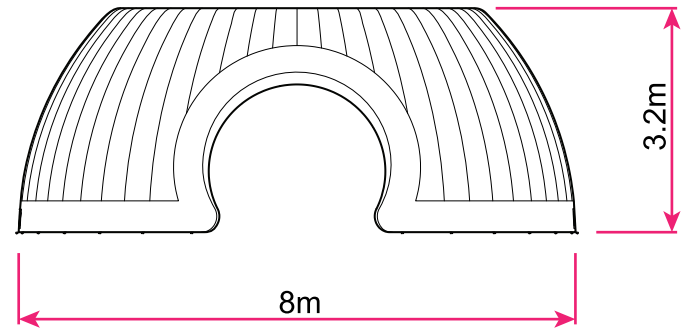

Fan positioning available at 4 points at the sides of the structure - SEE DETAIL 2

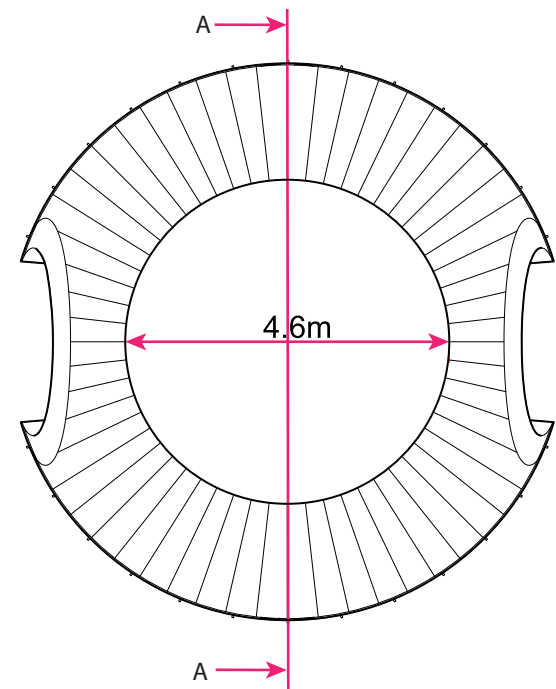

# General Arrangement (10m)

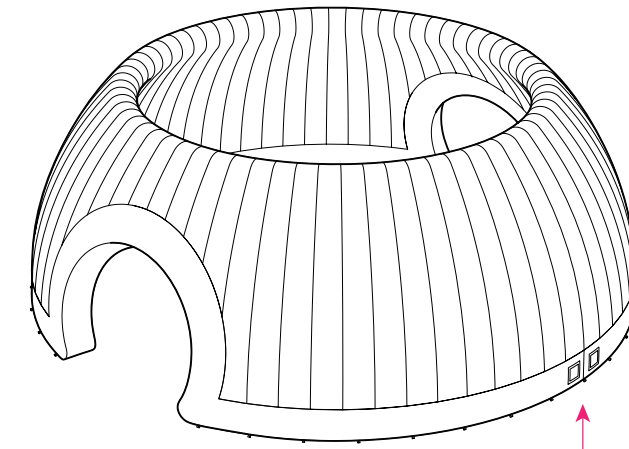
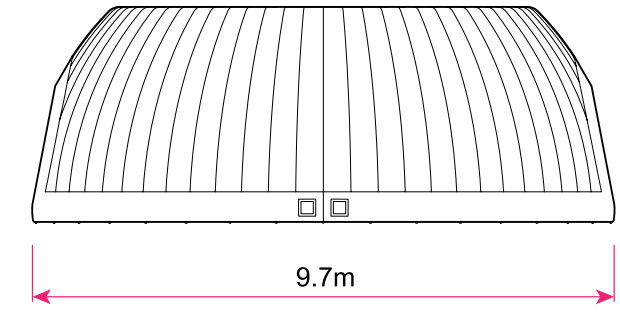
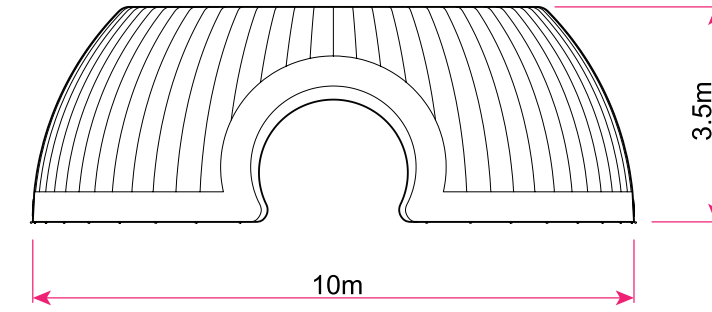

Fan positioning available at 4 points at the sides of the structure - SEE DETAIL 2

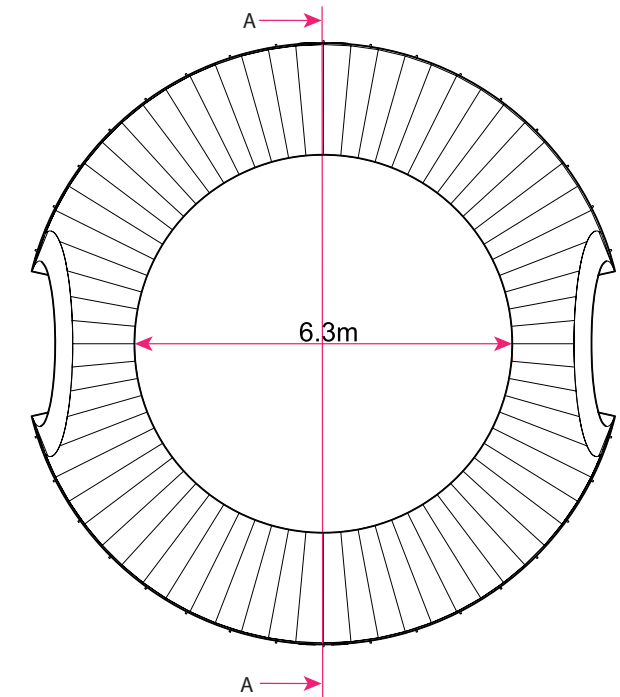

# Product Specification (6m)

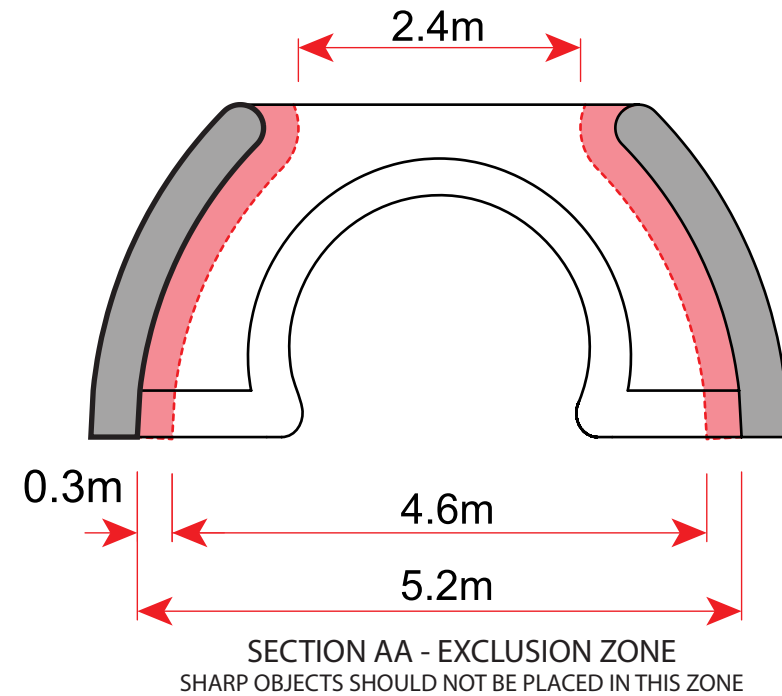
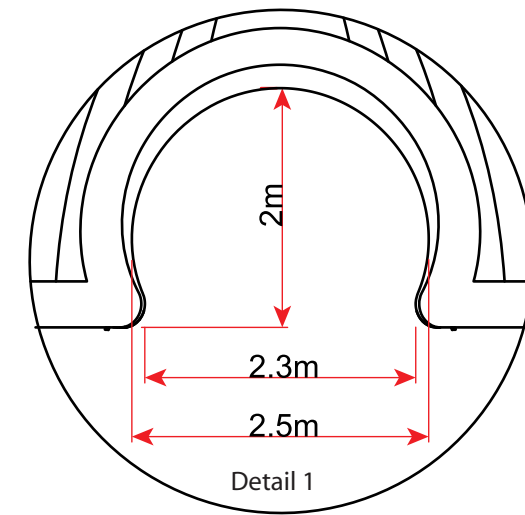
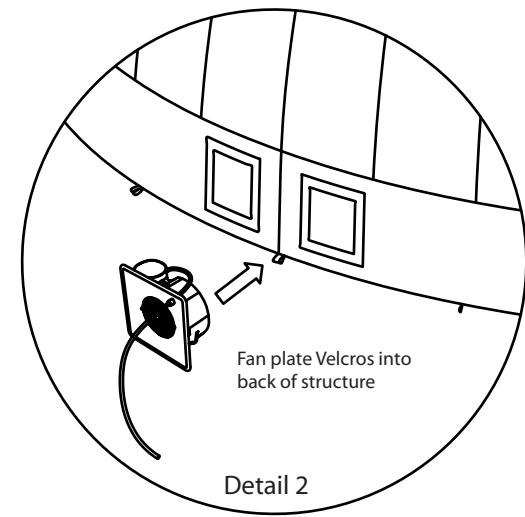

# Product Specification (6m)

## PACKAGE

- 1 x Structure, 1 x Packing Bag, 2x FG 6 Fan

## STRUCTURE

- Packed Size:** • 500mm x 500mm x 400mm (est.)
- Packed Weight:** • 25kg (est.)
- Inflated Size:** • External - L6 m x W6m x H 2.8m  
• Internal - L5.2m x W5.2 x H 2.8m

- Internal Floor Area:** • 21m<sup>2</sup>
- Plot Size Required:** • 6.5m x 6.5m plus
- Entrance/Exit Size:** • W2.3m x 2m (for full dimensions refer to GA)
- Fabrics:** • rip stop nylon FR treated
- Colors:** • Combinations of white/black/silver
- Ground Fixings:** • Available upon request

**Please Note:** Information is correct at time of publication. Inspire Inflatables accept no responsibility for variations in dimensions or weights. Inspire Inflatables reserve the right to alter any dimensions or weights at any time without prior notice.

## POWER & FANS

- Fans:** • 2x FG6 fan
- Min Secure Power:** • 120v
- Fan Weight:** • 4kg per fan
- Fan Dimensions:** • 304mm x 304mm x 203mm

**Please Note:** It is the responsibility of the client or site management to ensure that the power used for fans is secure and tested. The above power consumption is for fans only and covers no extra electrical items. No other item should be connected to the fan power lines. The company accepts no responsibility for damages to equipment or damages to inflatable structures, injuries to persons or loss of earnings due to electrical power faults.

## INSTALLATION & DERIG

- Crew:** • 1 persons (min)
- Set Up Time:** • From 20 minutes
- Inflation Time:** • 10 mins for structure when fixed
- Derig Time:** • From 20 minutes

## PRODUCT ENHANCEMENTS

- Branding • Temporary/ Permanent/ Banners / Printed Covers
- Ground Anchor Fixing • Glazed Doors • Lighting • Flooring
- Custom Colored Fabric • All Spares of Basic Package

**Please Note:** Refer to separate later page for more detail on product enhancement. Please note the above technical data can be effected by additional product enhancements. The company reserves the right to add or remove product enhancements from product range without prior notice.



# Product Specification (8m)

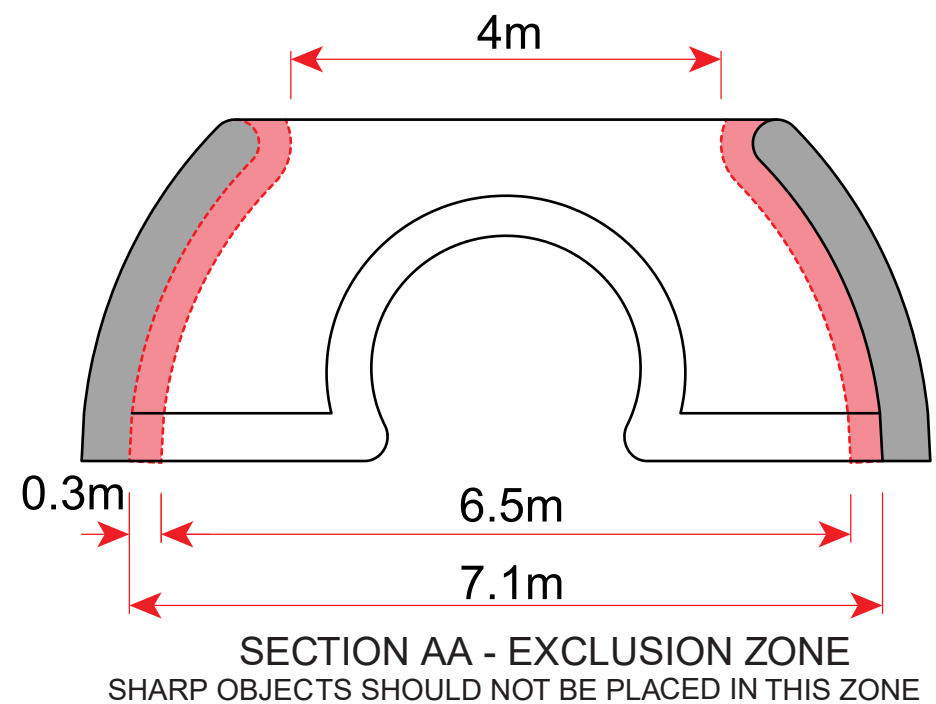
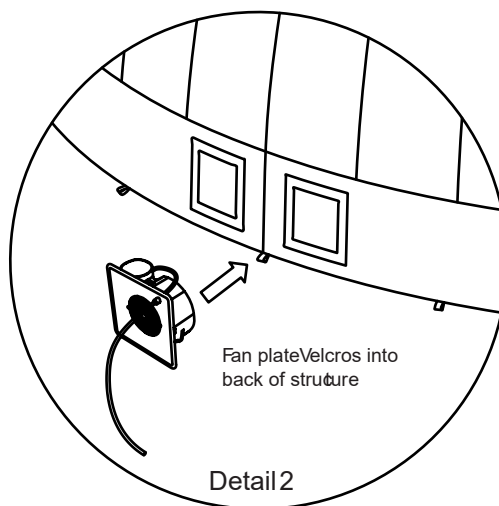
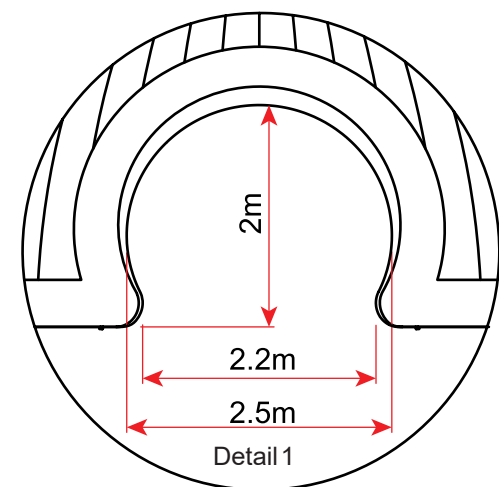

# Product Specification (8m)

## PACKAGE

- 1x Structure, 1x Packing Bag, 3x FG6 fans

## STRUCTURE

- Packed Size:** • 700mm x 500mm x 500mm (est.)
- Packed Weight:** • 30kg (est.)
- Inflated Size:** • External - L8 m x W8m x H3.2m  
• Internal - L7.1m x W7.1m x H3.2m

- Internal Floor Area:** • 39.5m<sup>2</sup>
- Plot Size Required:** • 8.5m x 8.5m plus
- Entrance/Exit Size:** • 2.0m x 2m (for full dimensions refer to GA)
- Fabrics:** • rip stop nylon FR treated
- Colors:** • Combinations of white/black/silver
- Ground Fixings:** • Available upon request

**Please Note:** Information is correct at time of publication. Inspire Inflatables accept no responsibility for variations in dimensions or weights. Inspire Inflatables reserve the right to alter any dimensions or weights at any time without prior notice.

## POWER & FANS

- Fans:** • 3x FG 6 fans
- Min Secure Power:** • 120v
- Fan Weight:** • 4kg per fan
- Fan Dimensions:** • 304mm x 304mm x 203mm

**Please Note:** It is the responsibility of the client or site management to ensure that the power used for fans is secure and tested. The above power consumption is for fans only and covers no extra electrical items. No other item should be connected to the fan power lines. The company accepts no responsibility for damages to equipment or damages to inflatable structures, injuries to persons or loss of earnings due to electrical power faults.

## INSTALLATION & DERIG

- Crew:** • 1 persons (min)
- Set Up Time:** • From 25 minutes
- Inflation Time:** • 10 mins for structure when fixed
- Derig Time:** • From 25 minutes

## PRODUCT ENHANCEMENTS

- Branding • Temporary/ Permanent/ Banners / Printed Covers
- Ground Anchor Fixing • Glazed Doors • Lighting • Flooring
- Custom Colored Fabric • All Spares of Basic Package

**Please Note:** Refer to separate later page for more detail on product enhancement. Please note the above technical data can be effected by additional product enhancements. The company reserves the right to add or remove product enhancements from product range without prior notice.



# Product Specification (10m)

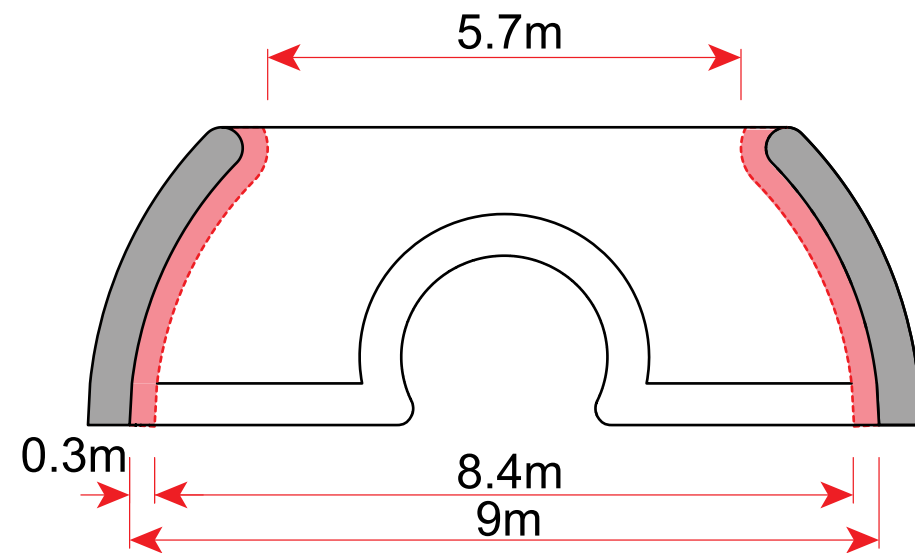
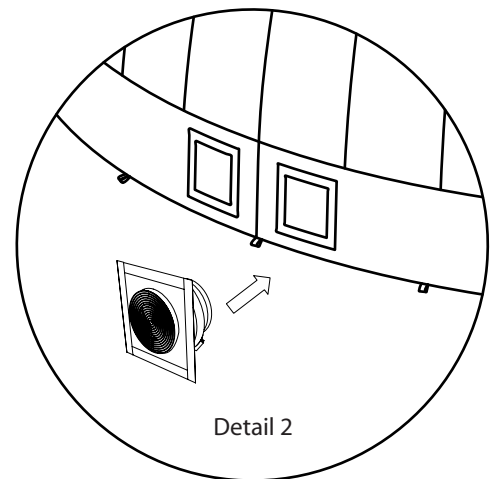
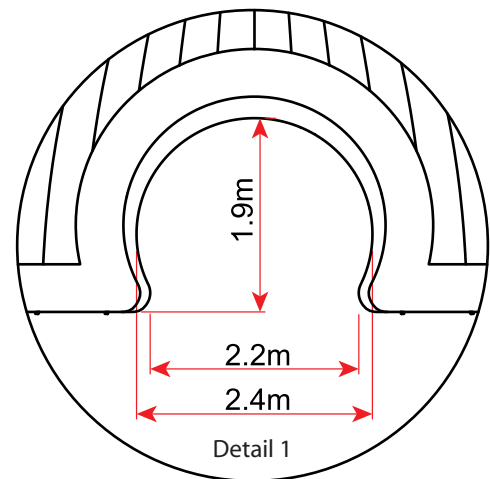

SECTION AA - EXCLUSION ZONE  
SHARP OBJECTS SHOULD NOT BE PLACED IN THIS ZONE

# Product Specification (10m)

## PACKAGE

- 1x Structure, 1x Packing Bag, 4x FG6 Fans

## STRUCTURE

- Packed Size:** • 800mm x 600mm x 500mm (est.)
- Packed Weight:** • 45kg (est.)
- Inflated Size:**
  - External - L10m x W10m x H3.5m
  - Internal - L9 m x W9 mx H3.5m
- Internal Floor Area:** • 63.5m<sup>2</sup>
- Plot Size Required:** • 10.5m x 10.5m plus
- Entrance/Exit Size:** • 2.2m x 1.9m (for full dimensions refer to GA)
- Fabrics:** • rip stop nylon FR treated
- Colors:** • Combinations of white/black/silver
- Ground Fixings:** • Available upon request

**Please Note:** Information is correct at time of publication. Inspire Inflatables accept no responsibility for variations in dimensions or weights. Inspire Inflatables reserve the right to alter any dimensions or weights at any time without prior notice.

## POWER & FANS

- Fans:** • 4x FG6 fans
- Min Secure Power:** • 120v
- Fan Weight:** • 4kg per fan
- Fan Dimensions:** • 304mm x 304mm x 203mm

**Please Note:** It is the responsibility of the client or site management to ensure that the power used for fans is secure and tested. The above power consumption is for fans only and covers no extra electrical items. No other item should be connected to the fan power lines. The company accepts no responsibility for damages to equipment or damages to inflatable structures, injuries to persons or loss of earnings due to electrical power faults.

## INSTALLATION & DERIG

- Crew:** • 1-2 person (min)
- Set Up Time:** • From 30 minutes
- Inflation Time:** • 10 mins for structure when fixed
- Derig Time:** • From 30 minutes

## PRODUCT ENHANCEMENTS

- Branding • Temporary/ Permanent/ Banners / Printed Covers
- Ground Anchor Fixing • Glazed Doors • Lighting • Flooring
- Custom Colored Fabric • All Spares of Basic Package

**Please Note:** Refer to separate later page for more detail on product enhancement. Please note the above technical data can be effected by additional product enhancements. The company reserves the right to add or remove product enhancements from product range without prior notice.



# Product Capacity (6m)

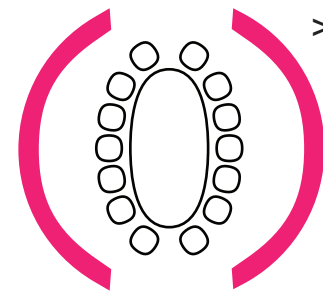

> DINING/MEETING  
14 SEATS AND  
TABLE



> CHILL OUT SPACE  
16 PEOPLE

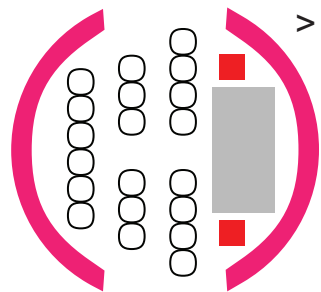

> CONFERENCE  
2M X 1M PODIUM  
20 SEATS

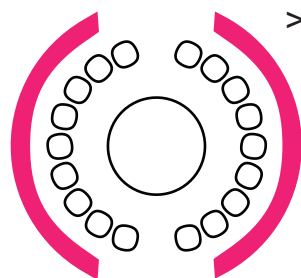

> ARENA  
14 SEATS

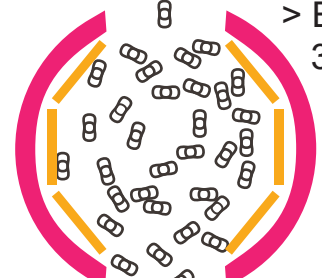

> EXHIBITION  
33 PEOPLE STANDING

● Structure Footprint    🍷 Table + 10 Seats    ● Stage    ■ Speakers    🟡 Exhibit    👤 People standing.

# Product Capacity (8m)

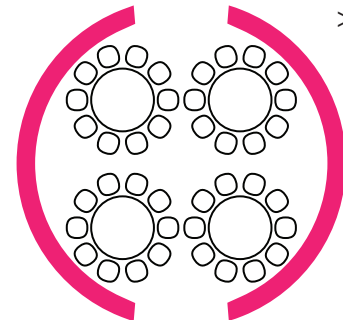

> DINING  
40 SEATS AND TABLES

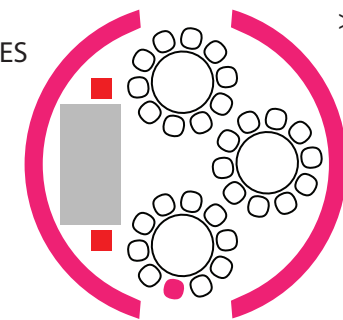

> DINING AND PODIUM  
30 SEATS AND TABLES

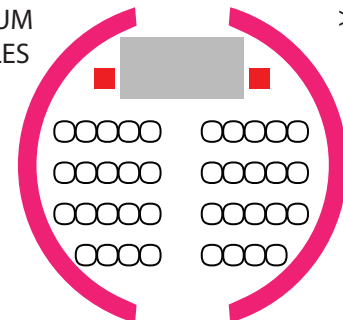

> CONFERENCE  
3M X 1.5M PODIUM  
38 SEATS

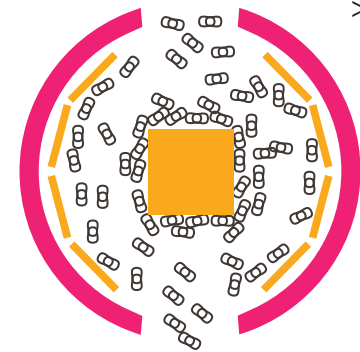

> EXHIBITION  
60 PEOPLE STANDING

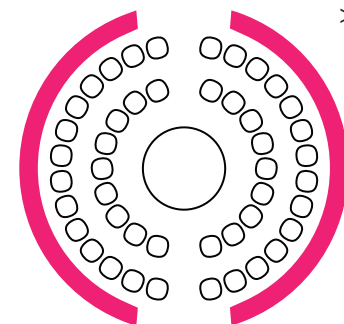

> ARENA  
46 SEATS

● Structure Footprint    🍷 Table + 10 Seats    ● Stage    ■ Speakers    🟡 Exhibit    👤 People standing.

# Product Capacity (10m)

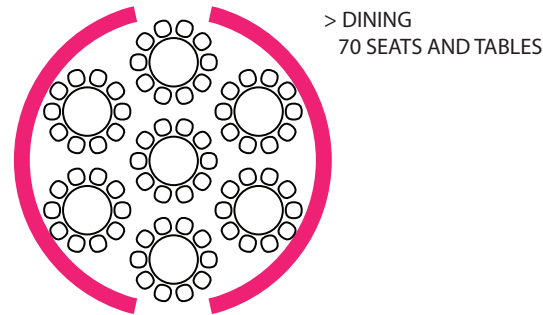

> DINING  
70 SEATS AND TABLES

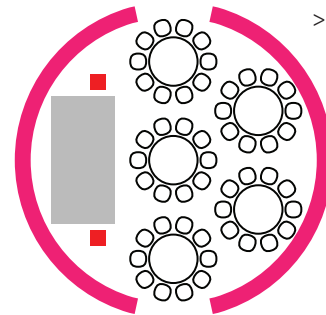

> DINING AND PODIUM  
50 SEATS AND TABLES

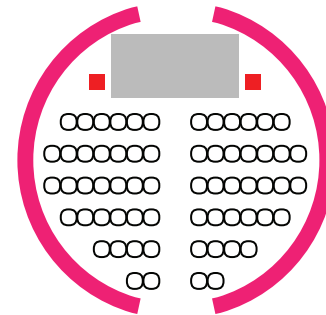

> CONFERENCE  
4M X 2M PODIUM  
64 SEATS

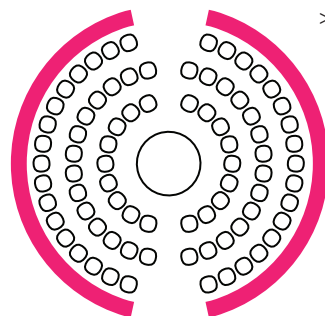

> ARENA  
80 SEATS

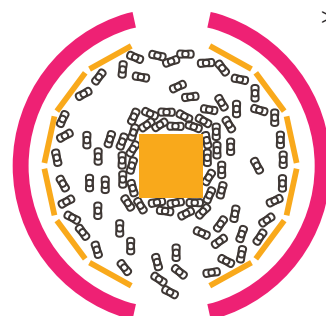

> EXHIBITION  
90 PEOPLE STANDING

- Structure Footprint
- Table + 10 Seats
- Stage
- Speakers
- Exhibit
- People standing.

# Product Enhancement

## Branding

Branding can be applied permanently to any of the Inflatable structures as screen print or digital printing at the source of production.

Temporary branding can be added as vinyl or Dacron adhesive panels at any stage. Please note that not all artwork is suitable for printing on our structure range. It is advised sample artwork be supplied in an .eps format so we can advise the best solution. Full replaceable covers are available to the range. These can be branded and printed to ensure your structure matches your brand.

## Custom colors and materials

All our structures are manufactured in ripstop nylon and reinforced PVC. As standard they are made in white and grey. Although a full color range is available, this may alter lead times and costs.

Other materials are available and we are happy to discuss specific needs / projects and will advise on what we feel is the most appropriate solution. All fabrics are tested for performance of flammability for textiles used in the construction of marquees and similar textiles structures to standards: BS 7837:1996 / BS 5438:1989.

## Lighting

As an optional extra we can provide internal LED lighting systems which will transform the look and feel of your inflatable structure. The ambient lighting effect can be either one color change or mixed to produce your perfect environment.

## Flooring

Flooring is available upon request and is offered to suit all event needs. We offer simple snap lock flooring. This light weight flooring is ideal for grass and concrete. It can be further enhanced by adding a finishing carpet.

## Transport

By its nature an inflatable structure packs down to considerably less than its inflated size. The largest of our range packs down to less than 2M<sup>3</sup> which makes the structures ideal to store and use again. Each product will be supplied in its own storage bag and will be easily transported in an out of any venue.

## Warranty

Inspire offers a 12 month warranty on the manufacture process and materials if the user manual and install guides are followed. Due to the nature of weather and installation conditions, Inspire reserves the right to carry out an onsite inspection and report which way the warranty will be met.

