

Airoof

Data Sheet

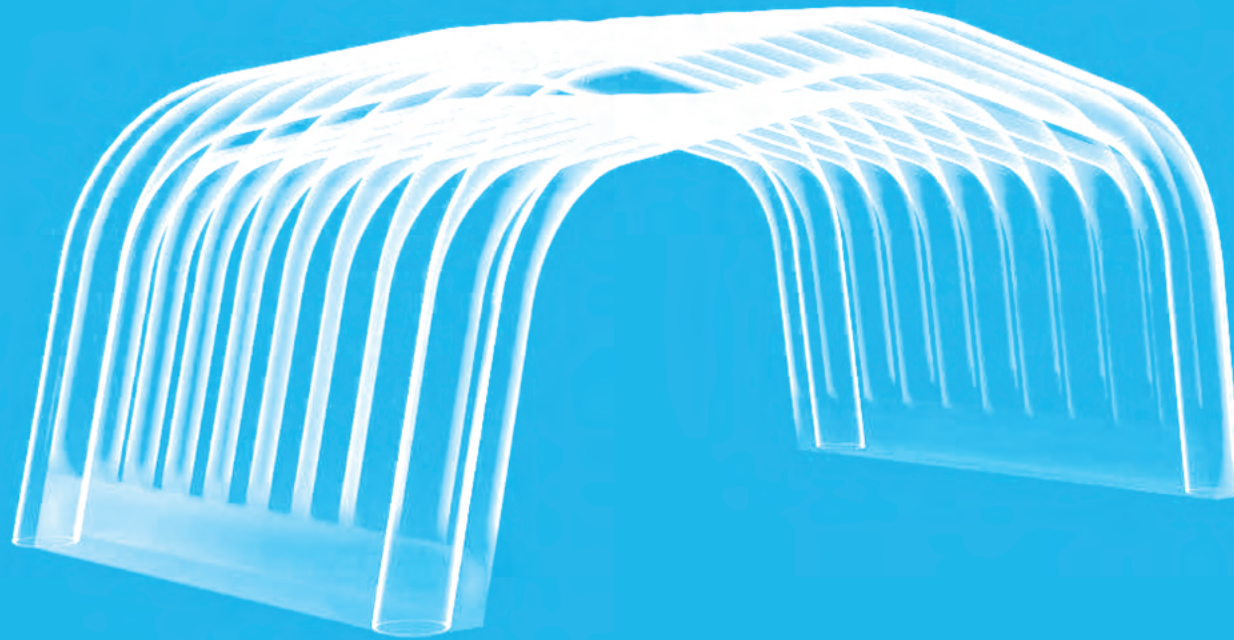

InspireInflatables

Visionary Inflatable Designs

Product Variations

Inspire is a brand new range of high performance, beautifully designed and practical temporary event structures

Traditionally inflatable structures have been light weight and open to abuse from weather and more importantly the wind. The new range offers greatly improved performance through intensive design and engineering. Inspire inflatable event structures can withstand wind speeds and gusts up to 55 mph therefore ensuring your event is not effected at anytime of the year. Creatively designed Inspire products are the worldwide leader in inflatable structures. **Inspire Airoof range includes:**

Inspire Airoof Air-Beam collection

The highest rated inflatable temporary dome on the market can be used in winds up to 55 mph. This is because of the regulated pressurised air beams which provide a solid support skeleton to the overall structure. An Inspire Airoof offers contemporary look and market leading performance.

Inspire Air Airoof standard collection

The standard Inspire Airoof range offers the same high class finish and look and are the same product in every way, apart from he Air Beams. This efficient, professionally made unit offers a superb solution to any event.

The Inspire range of structures can be tailored to suit your event needs; we offer branding with options including direct print and replaceable printed covers. The Inspire range also offers great flexibility as all products can be seamlessly joined together, providing wonderful multi-room environments. We also offer a range of connecting tunnels to add a sleek finish to the event structure.



General Arrangement (6m)

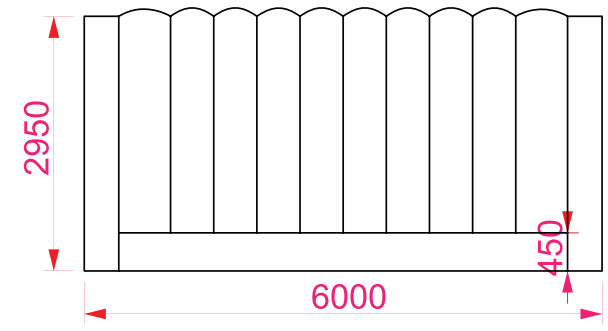

SIDE ELEVATION

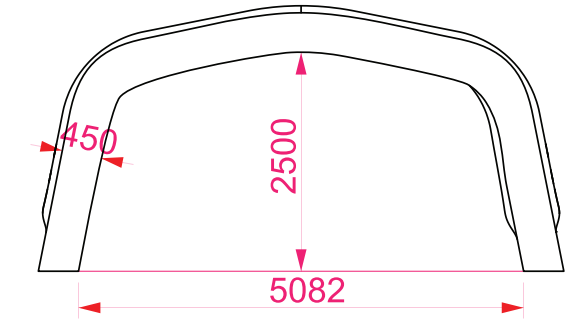

FRONT ELEVATION

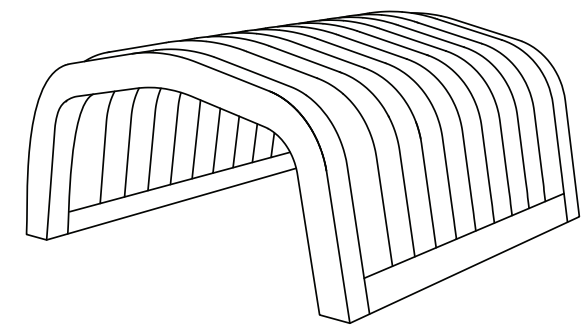

PERSPECTIVE VIEW

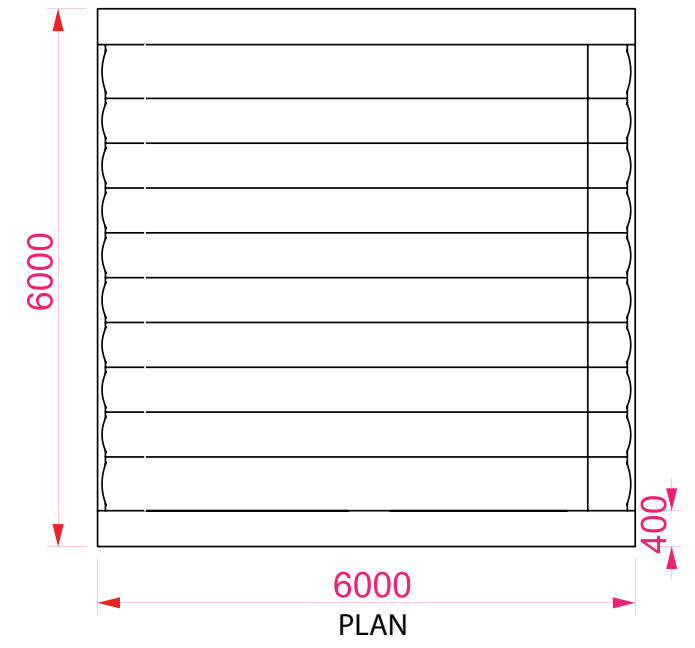

6000
PLAN



General Arrangement 12m

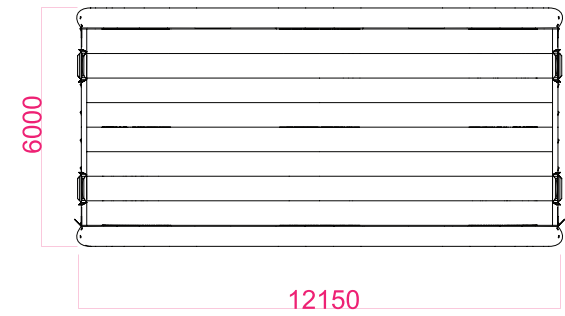

PLAN

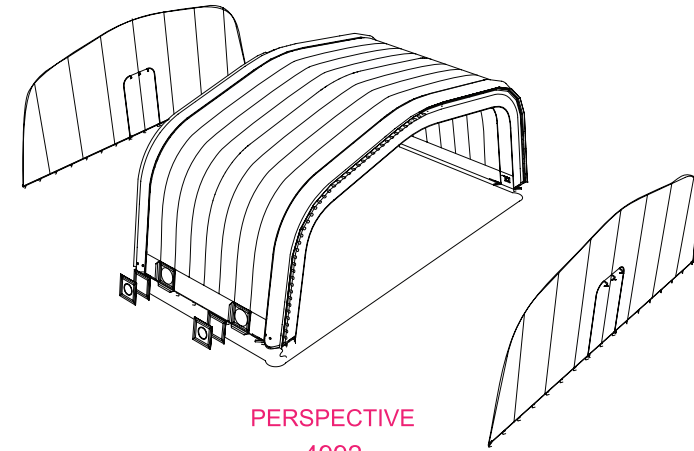

PERSPECTIVE

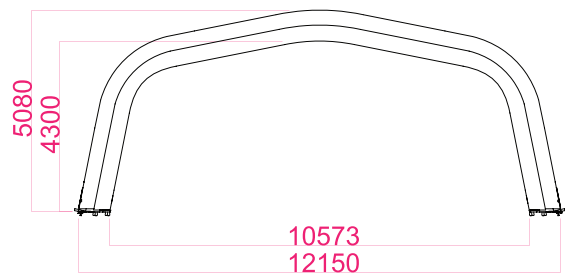

SIDE

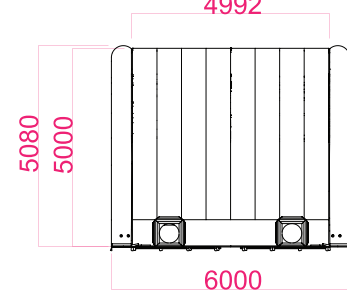

FRONT

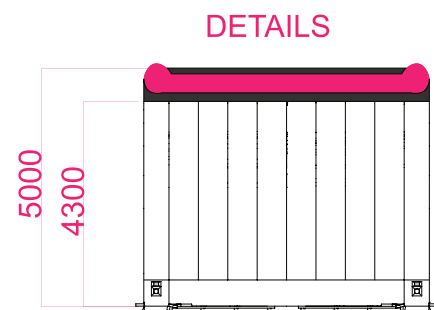
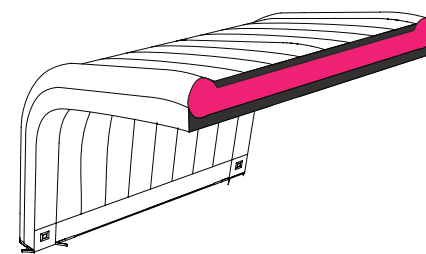

DETAILS

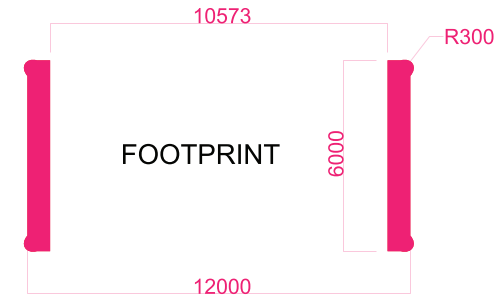

FOOTPRINT

General Arrangement Triad

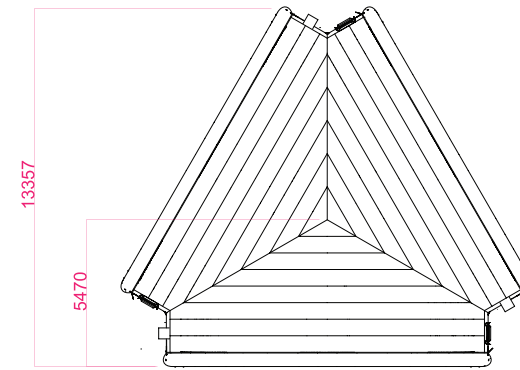

PLAN

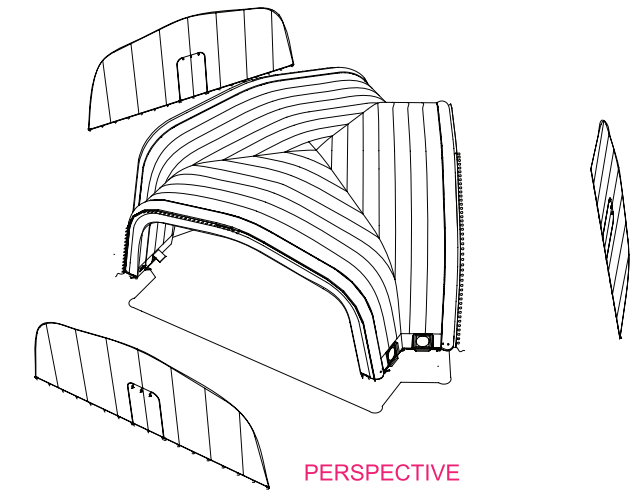

PERSPECTIVE

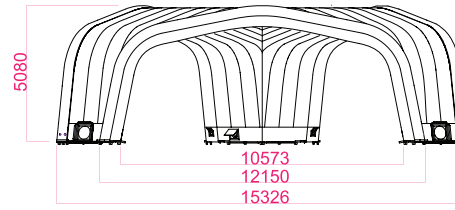

SIDE

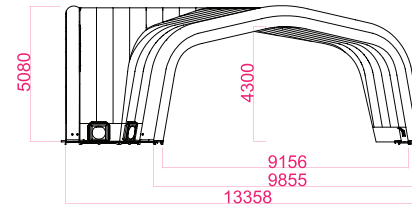

FRONT

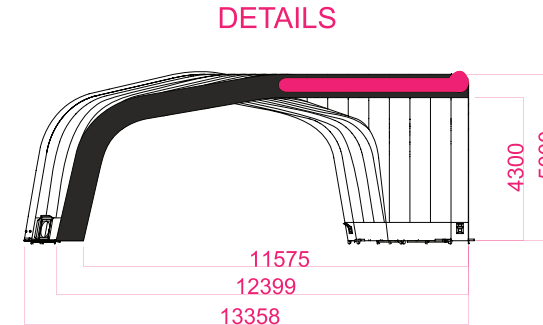
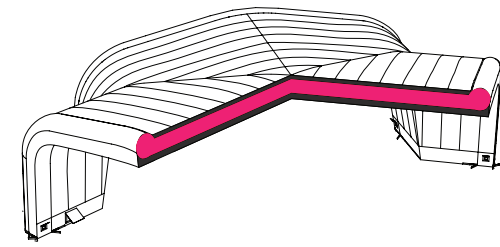

DETAILS

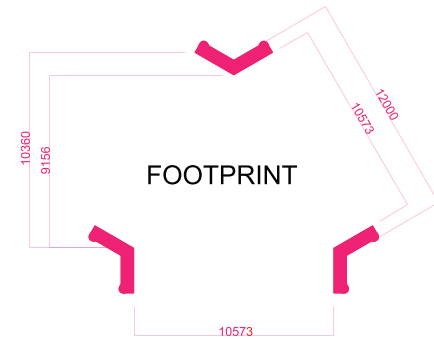

FOOTPRINT



General Arrangement Quad

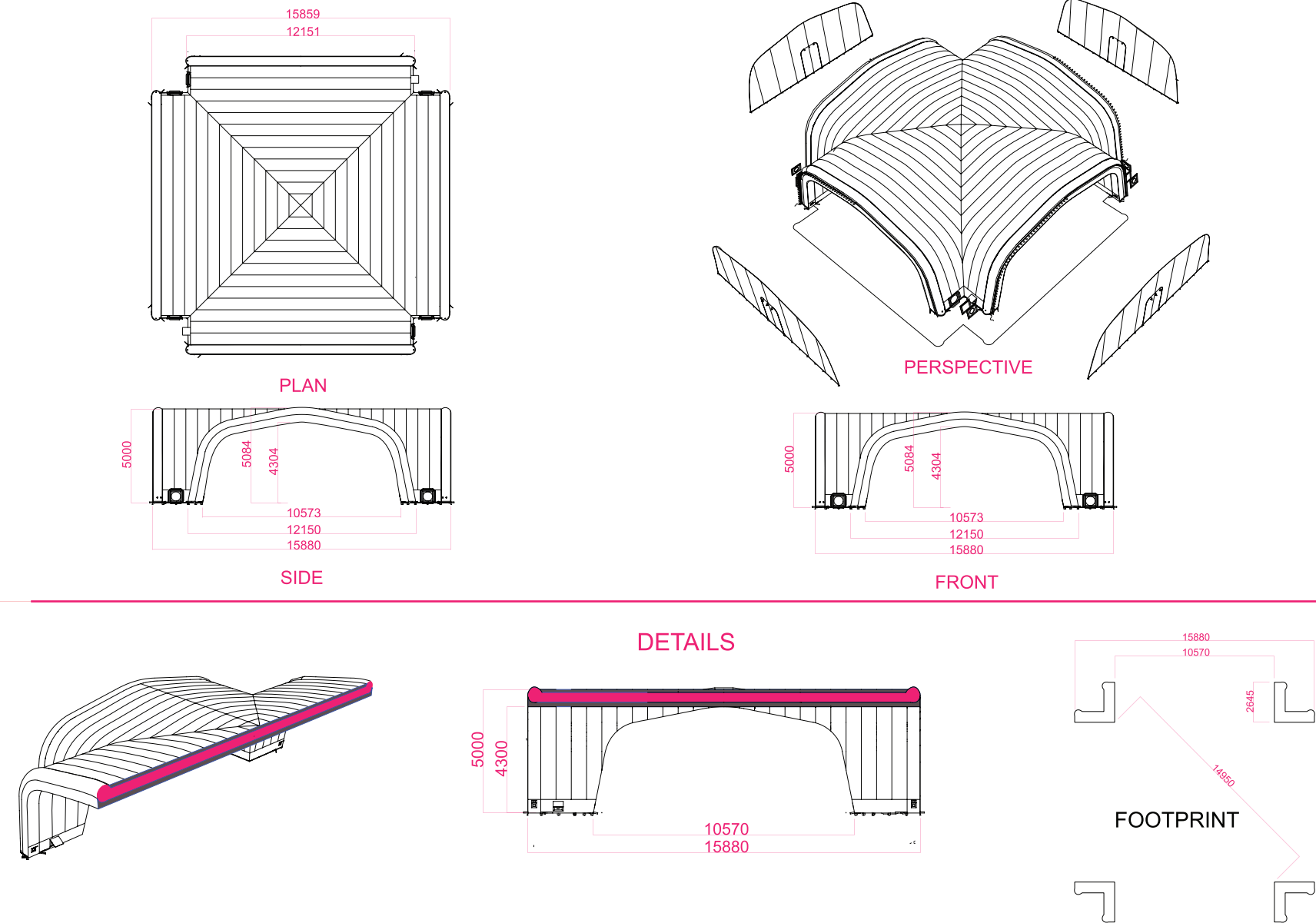

Product Accessories 12m

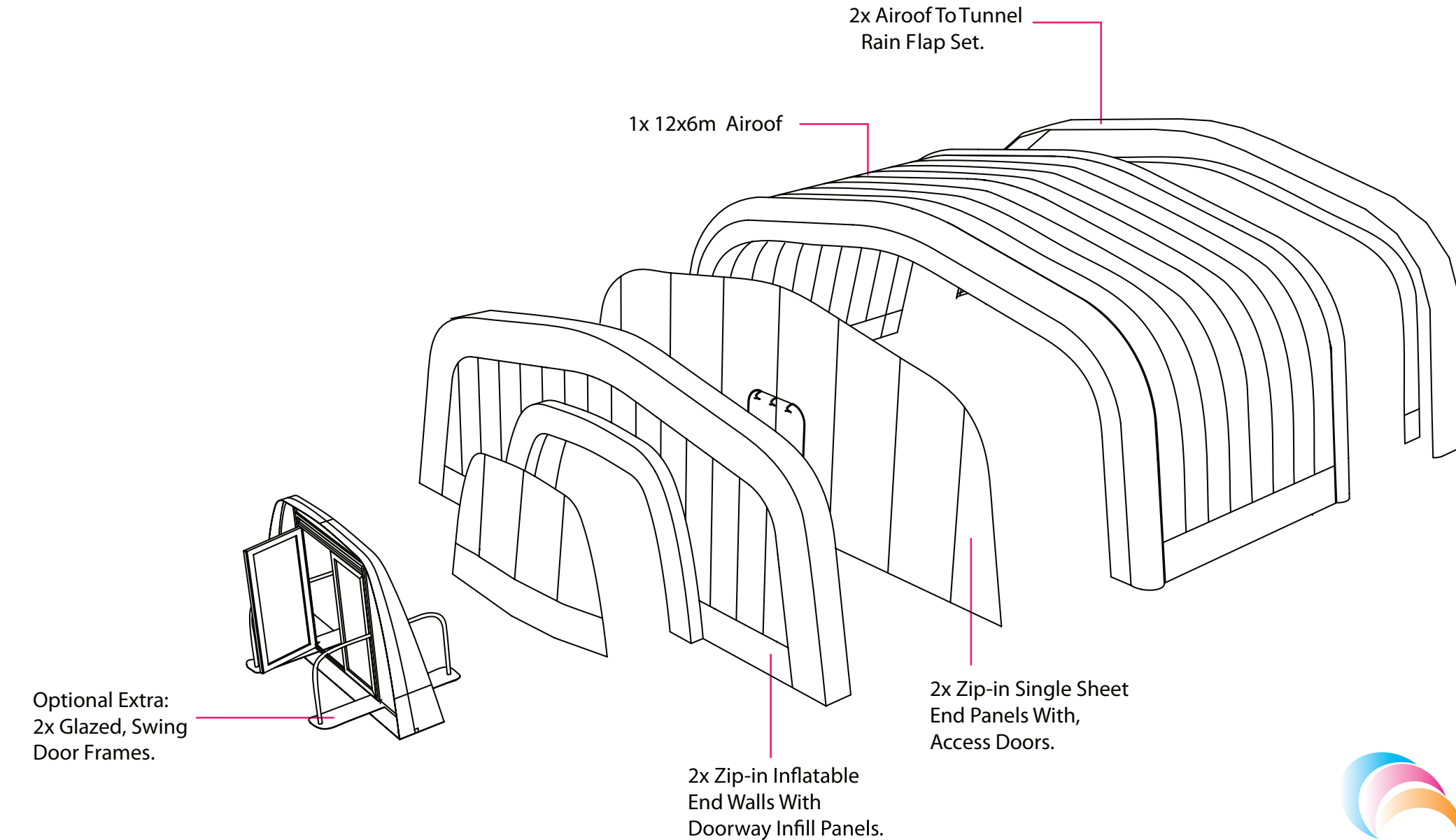

Product Accessories Triad

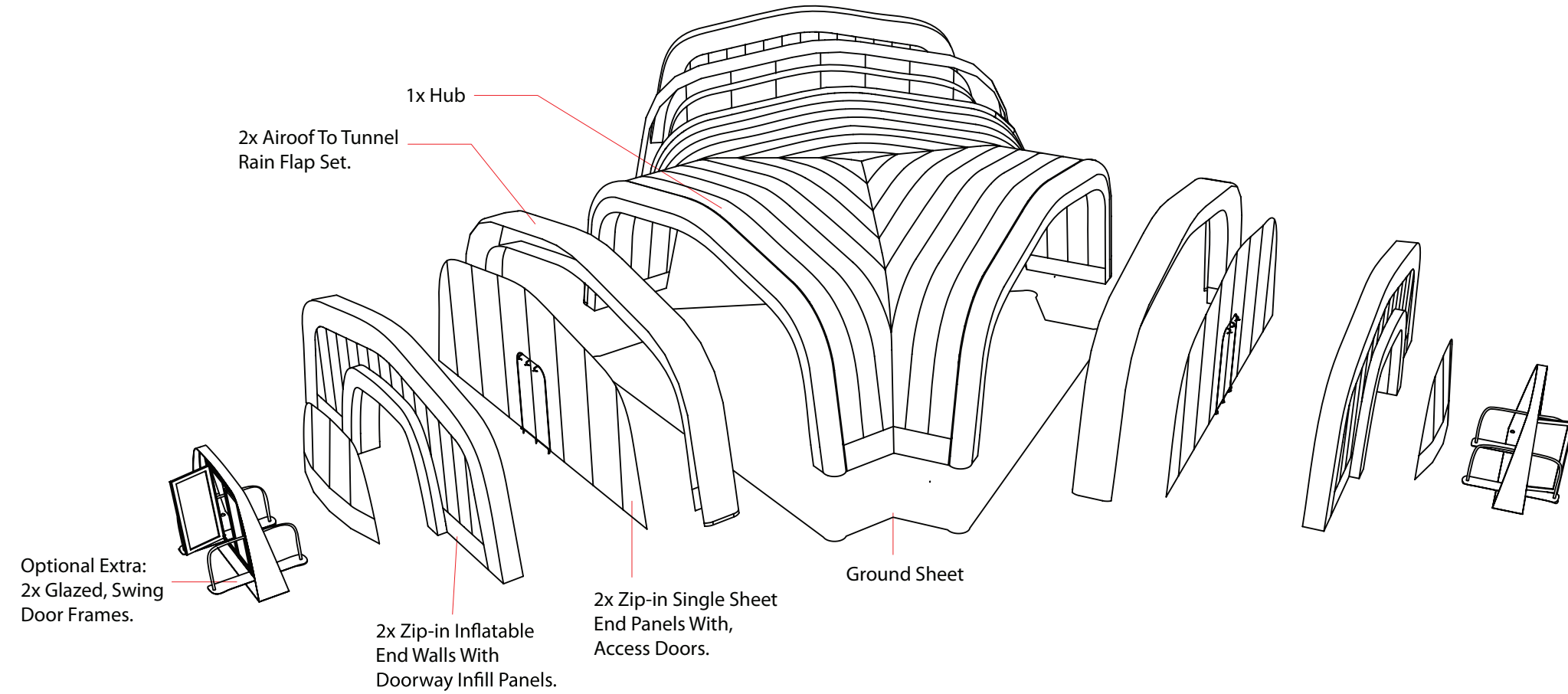

Product Accessories Quad

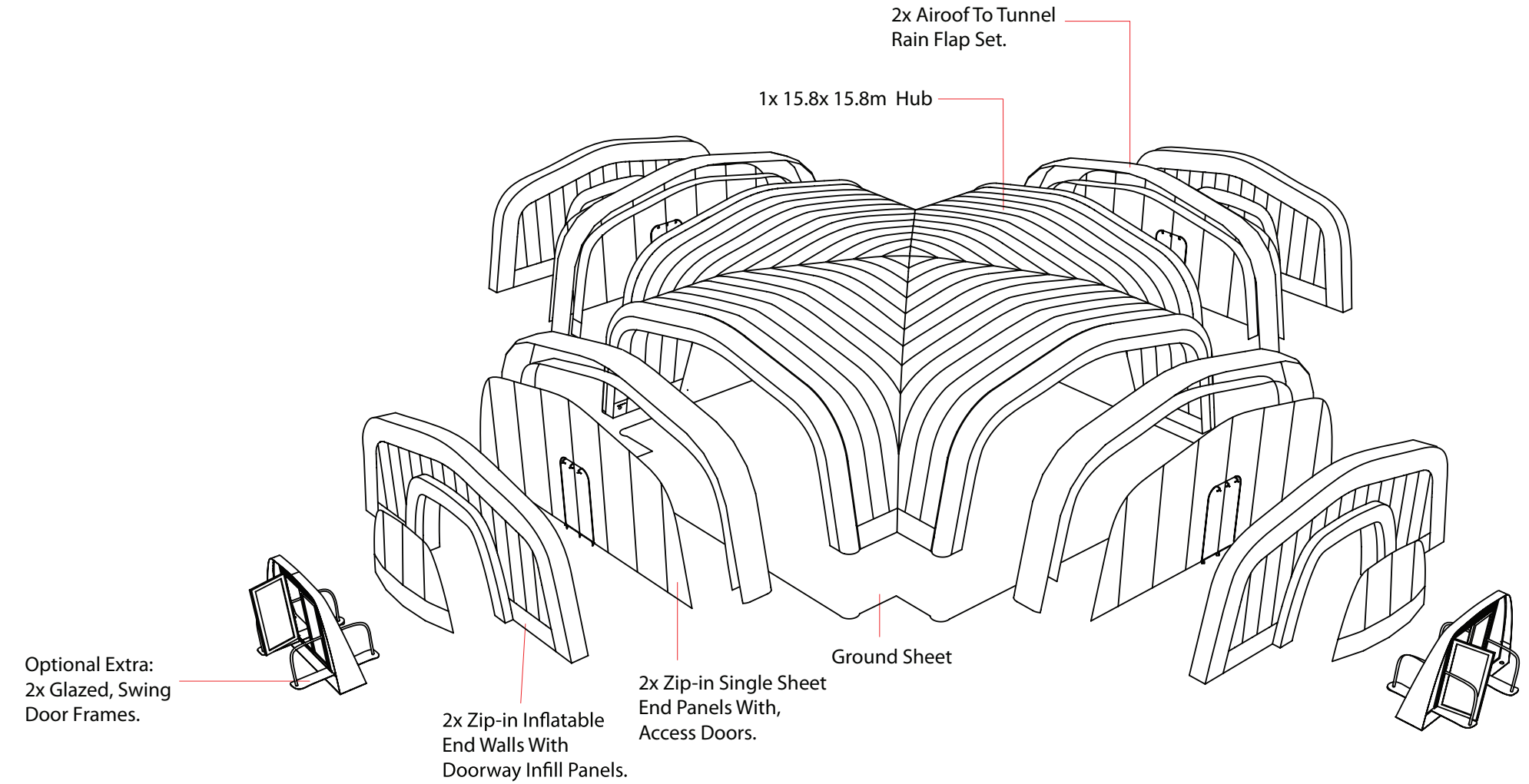

Product Specification 6m

PACKAGE

- 1x Structures, 1x Packing Bags, 2x Zip-in end panels with access doors
- 1 x connection rain flap sets, 2x FG12 fans

STRUCTURE

- Packed Size:** • 1x 600mm x 500mm x 400mm (est.)
- Packed Weight:** • 40kg (est.)
- Inflated Size:** • External - W6m x D6m x H2.95m
- Internal - W5.08m x D6m x H2.5m
- Internal Floor Area:** • 30.4m²
- Plot Size Required:** • 8m x 8m plus
- Entrance/Exit Size:** • W5.08m, H2.5m
- Fabrics:** • PVC, rip stop nylon FR treated
- Colors:** • Combinations of white/black/gray

Please Note: Information is correct at time of publication. The company accept no responsibility for variations in dimensions or weights. The company reserve the right to alter any dimensions or weights at any time without prior notice.

POWER & FANS

- Fans:** • 2x FG12 fans
- Pumps:** • 120v
- Fan Weight:** • 8kg per fan

Please Note: It is the responsibility of the client or site management to ensure that the power used for fans is secure and tested. The above power consumption is for fans only and covers no extra electrical items. No other item should be connected to the fan power lines. The company accepts no responsibility for damages to equipment or damages to inflatable structures, injuries to persons or loss of earnings due to electrical power faults.

INSTALLATION & DERIG

- Crew:** • 1 persons (min)
- Set Up Time:** • From 1 hours
- Inflation Time:** • 20 mins for structure when fixed
- Derig Time:** • From 1 hours

PRODUCT ENHANCEMENTS

- Branding Temporary/ Permanent / Banners / Printed Covers
- Ground Anchor Fixing • Glazed Doors • Lighting • Trussing • Flooring
- High Pressure Supporting Tube Frame • Custom Colored Fabric
- All Spares of Basic Package

Please Note: Refer to separate later page for more detail on product enhancement. Please note the above technical data can be effected by additional product enhancements. The company reserves the right to add or remove product enhancements from product range without prior notice.



Product Specification 12m

PACKAGE

- 1x Structures, 1x Packing Bags, 2x Zip-in end panels with access doors
- 1x connection rain flap sets, 4x FG12 fans

STRUCTURE

- Packed Size:** • 1x 1200mm x 800mm x 600mm (est.)
- Packed Weight:** • 100kg (est.)
- Inflated Size:** • External - W12m x D6m x H5m
- Internal - W10.6m x D6m x H4.3m
- Internal Floor Area:** • 63.4m²
- Plot Size Required:** • 14m x 8m plus
- Entrance/Exit Size:** • W4.08m, H2.2m
- Fabrics:** • PVC, rip stop nylon FR treated
- Colors:** • Combinations of white/black/gray

Please Note: Information is correct at time of publication. The company accept no responsibility for variations in dimensions or weights. The company reserve the right to alter any dimensions or weights at any time without prior notice.

POWER & FANS

- Fans:** • 4x 200W fan
- Pumps:** • 120v
- Fan Weight:** • 8 kg per fan

Please Note: It is the responsibility of the client or site management to ensure that the power used for fans is secure and tested. The above power consumption is for fans only and covers no extra electrical items. No other item should be connected to the fan power lines. The company accepts no responsibility for damages to equipment or damages to inflatable structures, injuries to persons or loss of earnings due to electrical power faults.

INSTALLATION & DERIG

- Crew:** • 1 persons (min)
- Set Up Time:** • From 2 hours
- Inflation Time:** • 20 mins for structure when fixed
- Derig Time:** • From 2 hours

PRODUCT ENHANCEMENTS

- Branding Temporary/ Permanent / Banners / Printed Covers
- Ground Anchor Fixing • Glazed Doors • Lighting • Trussing • Flooring
- High Pressure Supporting Tube Frame • Custom Colored Fabric
- All Spares of Basic Package

Please Note: Refer to separate later page for more detail on product enhancement. Please note the above technical data can be effected by additional product enhancements. The company reserves the right to add or remove product enhancements from product range without prior notice.



Product Specification Triad

PACKAGE

- 1x Structures, 1x Packing Bags, 2x Zip-in end panels with access doors
1 x connection rain flap sets, 3x FG12 fans

STRUCTURE

- Packed Size:** • 1x 1200mm x 800mm x 600mm (est.)
- Packed Weight:** • 105kg (est.)
- Inflated Size:** • External - W15.3m x D13.5m x H5m
• Internal - W15.3m x D15m x H4.3m
- Internal Floor Area:** • 12.4m²
- Plot Size Required:** • 16.5m x 15.5m plus
- Entrance/Exit Size:** • W10.6m, H4.3m
- Fabrics:** • PVC, rip stop nylon FR treated
- Colors:** • Combinations of white/black/gray

Please Note: Information is correct at time of publication. The company accept no responsibility for variations in dimensions or weights. The company reserve the right to alter any dimensions or weights at any time without prior notice.

POWER & FANS

- Fans:** • 3x FG12 fans
- Pumps:** • 120v
- Fan Weight:** • 8kg per fan

Please Note: It is the responsibility of the client or site management to ensure that the power used for fans is secure and tested. The above power consumption is for fans only and covers no extra electrical items. No other items should be connected to the fan power lines. The company accepts no responsibility for damages to equipment or damages to inflatable structures, injuries to persons or loss of earnings due to electrical power faults.

INSTALLATION & DERIG

- Crew:** • 1 persons (min)
- Set Up Time:** • From 1.5 hours
- Inflation Time:** • 20 mins for structure when fixed
- Derig Time:** • From 1.5 hours

PRODUCT ENHANCEMENTS

- Branding Temporary/ Permanent / Banners / Printed Covers
- Ground Anchor Fixing • Glazed Doors • Lighting • Trussing • Flooring
- High Pressure Supporting Tube Frame • Custom Colored Fabric
- All Spares of Basic Package

Please Note: Refer to separate later page for more detail on product enhancement. Please note the above technical data can be effected by additional product enhancements. The company reserves the right to add or remove product enhancements from product range without prior notice.



Product Specification Quad

PACKAGE

- 1x Structures, 1x Packing Bags, 2x Zip-in end panels with access doors
1 x connection rain flap sets, 4x FG12 fans

STRUCTURE

- Packed Size:** • 1x 1400mm x 1000mm x 800mm (est.)
- Packed Weight:** • 140kg (est.)
- Inflated Size:** • External - W15.8m x D15.8m x H5m
• Internal - W15.8m x D15.8m x H4.3m
- Internal Floor Area:** • 22.4m²
- Plot Size Required:** • 17.5m x 17.5m plus
- Entrance/Exit Size:** • W10.6m, H4.3m
- Fabrics:** • PVC, rip stop nylon FR treated
- Colours:** • Combinations of white/black/gray

Please Note: Information is correct at time of publication. The company accept no responsibility for variations in dimensions or weights. The company reserve the right to alter any dimensions or weights at any time without prior notice.

POWER & FANS

- Fans:** • 4x FG12 fan
- Pumps:** • 120v
- Fan Weight:** • 8kg per fan

Please Note: It is the responsibility of the client or site management to ensure that the power used for fans is secure and tested. The above power consumption is for fans only and covers no extra electrical items. No other items should be connected to the fan power lines. The company accepts no responsibility for damages to equipment or damages to inflatable structures, injuries to persons or loss of earnings due to electrical power faults.

INSTALLATION & DERIG

- Crew:** • 1 persons (min)
- Set Up Time:** • From 2 hours
- Inflation Time:** • 20 mins for structure when fixed
- Derig Time:** • From 2 hours

PRODUCT ENHANCEMENTS

- Branding Temporary/ Permanent / Banners / Printed Covers
- Ground Anchor Fixing • Glazed Doors • Lighting • Trussing • Flooring
- High Pressure Supporting Tube Frame • Custom Colored Fabric
- All Spares of Basic Package

Please Note: Refer to separate later page for more detail on product enhancement. Please note the above technical data can be effected by additional product enhancements. The company reserves the right to add or remove product enhancements from product range without prior notice.



Product Capacity 6m

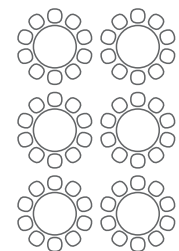

Restaurant Capacity:
6 Tables
60 Seats

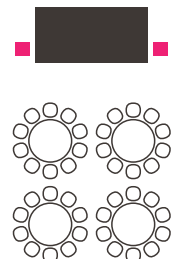

Caberet Capacity:
4x2m Stage
4 Tables
40 Seats

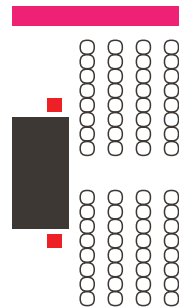

Conference Capacity:
4x2m Stage
56 Seats

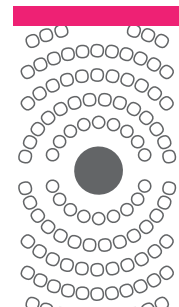

Arena Capacity:
2m Diameter Stage
102 Seats

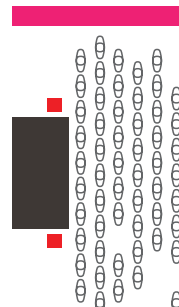

Concert Capacity:
4x2m Stage
126 People

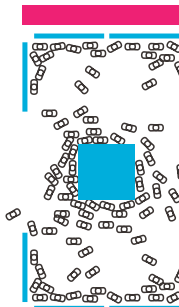

Exhibition Capacity:
9 Exhibition Stands
96 People

Product Capacity 12m

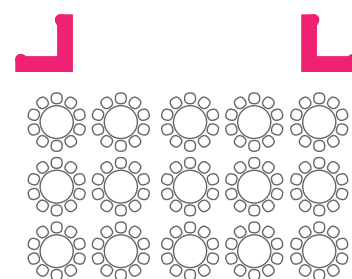

Restaurant Capacity:
15 Tables
150 Seats

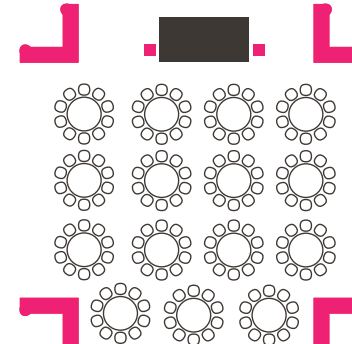

Caberet Capacity:
4x2m Stag
15 Tables
150 Seats

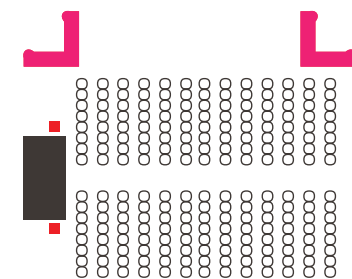

Conference Capacity:
4x2m Stage
160 Seats

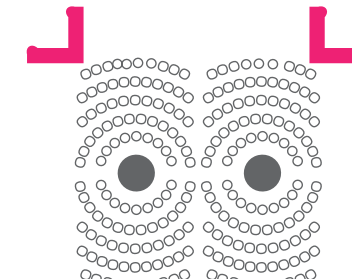

Arena Capacity:
2m Diameter Stage
160 Seats

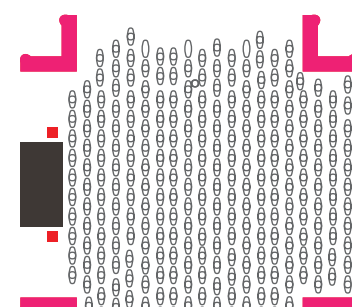

Concert Capacity:
4x2m Stage
340 People

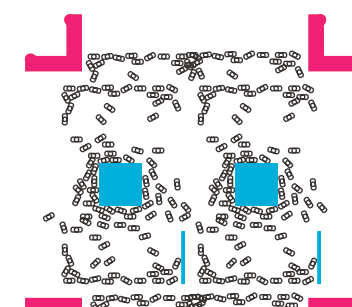

Exhibition Capacity:
18 Exhibition Stands
160 People

Product Capacity Triad

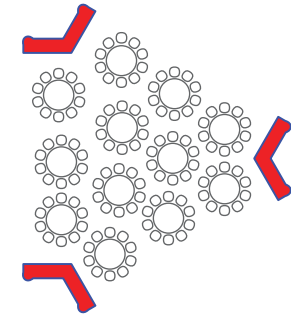

Restaurant Capacity:
12 Tables
120 Seats

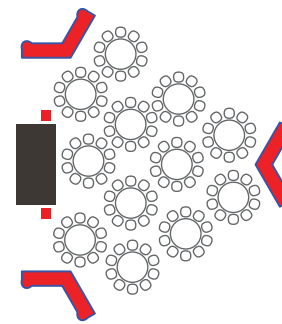

Caberet Capacity:
4x2m Stage
12 Tables
120 Seats

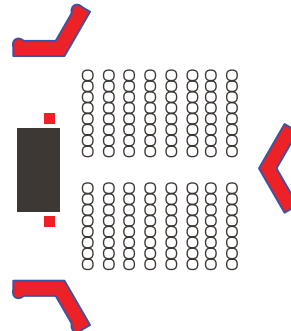

Conference Capacity:
4x2m Stage
128 Seats

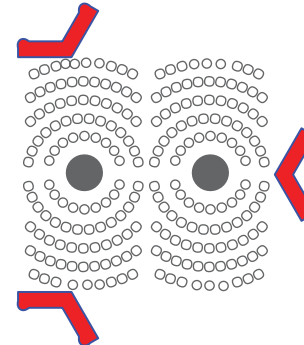

Arena Capacity:
2m Diameter Stage
200 Seats

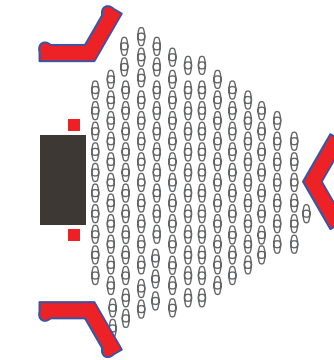

Concert Capacity:
4x2m Stage
200 People

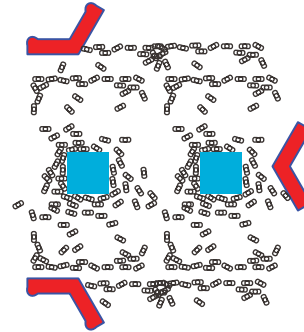

Exhibition Capacity:
18 Exhibition Stands
140 People

● Structure Footprint ○ Table + 10 Seats ● Stage ■ Speakers ■ Exhibit ○○ People standing.

Modularity Quad

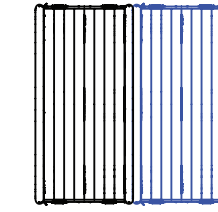

2 X AIR CANOPY



4 X AIR CANOPY
1 X HUB

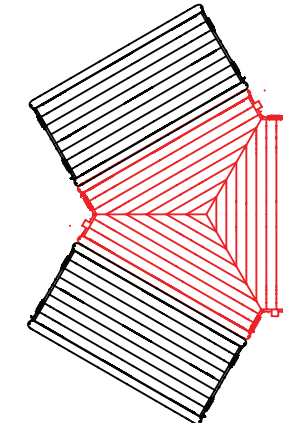
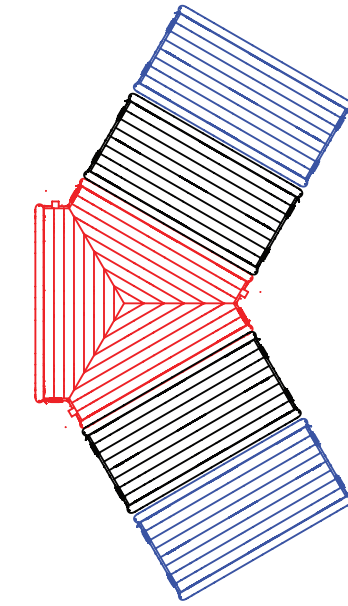

2 X AIR CANOPY
1 X HUB



3 X AIR CANOPY
1 X HUB



4 X AIR CANOPY
1 X HUB

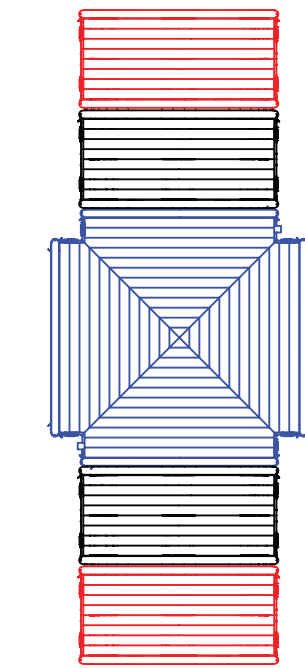

Product Enhancement

Branding

Branding can be applied permanently to any of the Inflatable structures as screen print or digital printing at the source of production.

Temporary branding can be added as vinyl or Dacron adhesive panels at any stage. Please note that not all artwork is suitable for printing on our structure range. It is advised sample artwork be supplied in an .eps format so we can advise the best solution. Full replaceable covers are available to the range. These can be branded and printed to ensure your structure matches your brand.

Custom colors and materials

All our structures are manufactured in ripstop nylon and reinforced PVC. As standard they are made in white and grey . Although a full color range is available, this may alter lead times and costs.

Other materials are available and we are happy to discuss specific needs / projects and will advise on what we feel is the most appropriate solution. All fabrics are tested for performance of flammability for textiles used in the construction of marquees and similar textiles structures to standards: BS 7837:1996 / BS 5438:1989

Lighting

As an optional extra we can provide internal LED lighting systems which will transform the look and feel of your inflatable structure. The ambient lighting effect can be either one colour change or mixed to produce your perfect environment.

Trussing

The M3 Air range of inflatable structures have been designed to be used as free standing products, trussing is not required to use them, however trussing can be added to enhance the environment. These can be used to hang PA equipment or other lighting options.

Doors & Closures

All of the Inspire range comes complete with zip in/ out doors as standard. Inspire also offers full aluminium double door systems. These provide fire safety openers and are fully lockable which provides increased security . The door systems are custom and made to be installed perfectly into our doorways.

Flooring

Flooring is available upon request and is offered to suit all event needs. We offer simple snap lock flooring. This offers light weight flooring and ideal for grass and concrete. It can be further enhanced by adding a finishing carpet.

Modularity

The entire Inspire range of Domes and Cubes can be joined together as the doorways are all standard. These can be jointed directly or by incorporating a space tunnel, these add an atmospheric walkway between the jointed structures and come in a range of lengths.

Transport

By its nature an inflatable structure packs down to considerably less than its inflated size. The largest of our range packs down to less than 2M³ which makes the structures ideal to store and use again. Each product will be supplied in its own storage bag and will be easily transported in an out of any venue.

Warranty

Inspire offers a 12 month warranty on the manufacture process and materials if the user manual and install guides are followed. Due to the nature of weather and installation conditions, Inspire reserves the right to carry out an onsite inspection and report which way the warranty will be met.

